

2025
Catalogue

NEUTRA



NEUTRA, Azienda che fonda le sue radici nel 1880 in Italia, nel cuore della Brianza, è specializzata nella fornitura e nella lavorazione di marmi e pietre naturali. Forte di oltre 140 anni di storia, il marchio è conosciuto e apprezzato per il suo know-how nella produzione di arredi dal carattere minimalista e rigoroso. Prodotti e complementi d'arredo realizzati con cura sartoriale grazie alle competenze tecnologiche e alla profonda conoscenza dei materiali sono da sempre i protagonisti delle collezioni dell'Azienda. Nel 2022 il corso di NEUTRA è giunto a un'importante svolta, con l'acquisizione del marchio da parte di Emanuele Chicco Busnelli, figlio di Piero Ambrogio Busnelli, fondatore storico di B&B Italia, una delle aziende che ha maggiormente innovato il panorama dell'arredo italiano e internazionale. L'ingresso di Chicco Busnelli nella proprietà innesta una vitalità nuova e inaugura per NEUTRA una stagione di ricerca nella direzione di un'eleganza senza tempo; da qui prende vita una nuova generazione di arredi in marmo, pietra e altri materiali, contraddistinti da una forte personalità: un'importante evoluzione segnata dalla nuova direzione creativa affidata allo studio di progettazione Migliore+Servetto.

NEUTRA is a company that traces its roots to 1880 in Italy, in the heart of Brianza, specialising in the supply and processing of marble and natural stone. With more than 140 years of history, the brand is known and appreciated for its knowledge in the production of furniture with a minimalist and rigorous style. Products and furnishing accessories are made with sartorial care leveraging the company's technological expertise and profound knowledge of materials which are focus of its collections. In 2022 NEUTRA's development reached an important turning point, when the brand was acquired by Emanuele Chicco Busnelli, son of Piero Ambrogio Busnelli, the historic B&B Italia founder. B&B Italia is one of the most innovative companies in the Italian and international furnishing scene. Chicco Busnelli's ownership provides new vitality and initiates a research process into "timeless elegance" - a new generation of furnishings in marble, stone and other materials, distinguished by a strong personality. This is an important evolution marked by the new creative direction entrusted to Migliore+Servetto design studio.

Contents

LIVING

POLTRONE / ARMCHAIRS	07	Artemisia
	13	La Grande Muraglia
LETTI / BEDS	18	Moon
LIBRERIE / BOOKSHELVES	23	Adym
	30	Pagina
SEDIE / CHAIRS	40	Artemisia
	46	Birky
COMPLEMENTI / COMPLEMENTS	52	Cavo
	55	Dima
	59	Micelio
CONSOLE	67	Branch
	72	Piega
TAVOLINI / SMALL TABLES	79	Coronae
	87	Delos
	95	Leaf
	100	Micelio
	106	Theia
DIVANI / SOFAS	110	La Grande Muraglia
	117	Ordos
	133	Sao Miguel
	156	Terrae
SGABELLI / STOOLS	170	Theia
CONTENITORI / STORAGE UNIT	173	Onis
TAVOLI / TABLES	181	Adym
	187	Aves
	192	Islas
	199	Leaf
	204	Minera
	210	Theia

Contents

OUTDOOR

POLTRONE/ARMCHAIRS	216	La Grande Muraglia Outdoor
COMPLEMENTI/COMPLEMENTS	220	Micelio Outdoor
TAVOLINI/SMALL TABLES	224	Coronae
	232	Leaf
	236	Micelio Outdoor
DIVANI/SOFAS	242	La Grande Muraglia Outdoor
TAVOLI/TABLES	252	Leaf

LIGHTING

LAMPADE/LAMPS	257	Eos
	261	Lente
	267	Meti
	272	Révérance
	279	Strobilo

BATHROOM

LAVABI/BASINS	287	Majesté
	294	Minimal M6
VASCHE/BATHTUBS	301	Alone
	306	Daphne
	312	Duo
	317	Easy
	322	Inkstone
	327	Majesté
	333	Spa
	338	Venus
COMPLEMENTI/COMPLEMENTS	344	Majesté
	348	Vivera

NEUTRA
Living

Artemisia

design by Stefano Gallizioli





Artemisia



Artemisia



ARTEMISIA Poltrona / Armchair
Pelle naturale di capra nera, Frassino spazzolato nero
Natural Goatskin black, Black Brushed Ash Wood

Artemisia

Seduta, design by Stefano Gallizioli

Artemisia è un incontro tra dolcezza e vigore, un'interpretazione moderna del coraggio e della determinazione. La sua silhouette, che richiama linee curve e femminili, racchiude un'anima forte - come quella della leggendaria comandante Artemisia, unica donna a guidare la flotta di Serse, a cui la collezione deve il nome. Le forme avvolgenti della seduta invitano al relax - enfatizzate dal rivestimento in pelliccia di Capra e Montone Rasato - ma è nelle linee decise della struttura che si esprime la sua personalità: una struttura solida in legno, che trasmette sicurezza e resistenza.

La sedia e la poltroncina Artemisia sono oggetti da vivere nel loro appeal ispirazionale, in grado di adattarsi a ogni ambiente con la loro eleganza senza tempo. Ogni dettaglio, ogni curva, racconta una storia di potere silenzioso e bellezza intrinseca, in un dialogo tra la delicatezza e l'energia, che rende questa seduta un pezzo unico, tanto nel design quanto nel significato.

Armchair designed by Stefano Gallizioli

An encounter between strength and softness, Artemisia is a modern interpretation of courage and determination. Its silhouette of curved, feminine lines encapsulates a strong soul just like that of Artemisia, legendary commander and only woman to have lead Xerxes' fleet, whom the collection is named after. With its enveloping shape, sheepskin and fur, the seat invites you to relax but its personality is expressed in the strong structural lines: a solid wooden frame conveying security and strength.

The Artemisia chair and armchair, with their ability to adapt in any environment, are inspirational items to experience and timelessly elegant. Every detail and curve tells a story of silent power and intrinsic beauty in a dialogue between delicacy and energy, making the Artemisia chair not only unique in its design but in its meaningfulness.

Artemisia

ARTA001 Artemisia Poltrona 85x85x70 Frassino Spazzolato Nero
Artemisia Armchair 85x85x70 Black Brushed Ash

ARTA002 Artemisia Poltrona 85x85x70 Frassino Spazzolato Naturale
Artemisia Armchair 85x85x70 Natural Brushed Ash

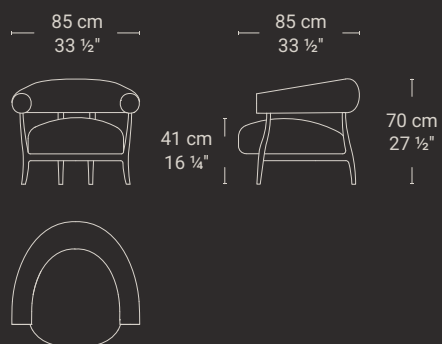

La Grande Muraglia

design by Mario Bellini







LGM Poltrona / Armchair
Marmo Travertino Romano, Tessuto Alpaca /
Travertino Romano marble, Alpaca Fabric

La Grande Muraglia

Poltrona, design by Mario Bellini

EDIZIONE LIMITATA 50 PEZZI

La collezione è composta da un divano (a due o a tre posti) e da una poltrona, caratterizzati da una struttura in Travertino Romano (disponibile anche in altre varianti di marmo) che accoglie le avvolgenti imbottiture di sedute, braccioli e schienali. I montanti e il telaio si identificano con i pilastri e l'architrave di un immaginario edificio monumentale, in contrapposizione dialettica con gli elementi morbidi ed avvolgenti della seduta che accolgono il corpo come in un abbraccio.

La connotazione fortemente architettonica degli elementi di seduta non pregiudica in alcun modo il comfort e la flessibilità nell'uso. Bellini rilegge le forme scultoree di La Grande Muraglia disegnando oggi dei veri e propri modi di vivere le sedute in un'ottica contemporanea, pensando alla lettura, al riposo, alla meditazione.

Le sedute de La Grande Muraglia sono disponibili anche in versione outdoor.

Armchair designed by Mario Bellini

LIMITED EDITION 50 PIECES

The collection consists of a two- or three-seat sofa and an armchair, made of a Travertino Romano marble frame (available in other marble options). The structure houses the enveloping upholstery of the seats, armrests and backrests. The uprights and frame are identified with the pillars and architrave of an imaginary monumental building, in dialectical contrast with the seat's soft, enveloping elements that embrace the body.

The strongly architectural reference of the seats does not compromise comfort and flexibility. Bellini reinterprets La Grande Muraglia's sculptural forms, designing modern ways of experiencing seating for reading, resting, or meditating. The La Grande Muraglia seats are available in an outdoor variant.

specifiche prodotto/
product specifications

La Grande Muraglia

LAP003

LGM Poltrona 129x95x91

LGM Armchair 129x95x91

EDIZIONE LIMITATA 50 PZ. / LIMITED EDITION 50 PCS.

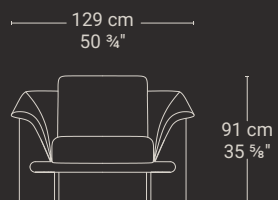

specifiche prodotto/
product specifications

Moon

design by Draw Studio

letti/beds





Moon



MOON Marmo Oyster White, Pelle naturale Nabuk
Oyster White marble, Nabuk Natural Leather

Moon

Letto, design by Draw Studio

L'armonia dei contrasti definisce Moon, un letto che trasforma il sonno in un'esperienza totale di benessere. Volumi ampi e generosi creano un'isola di morbidezza che sembra annullare la gravità; la testata è profonda e il sommier ultra-soffice, incorniciati da lembi in marmo che avvolgono il letto come una cornice protettiva. Marmo e pelle, materiali autentici e sensoriali, diventano parte essenziale di questa esperienza di riposo assoluto: da un lato la solidità eterna della pietra naturale, dall'altro superfici calde e piacevoli, che invitano ad abbandonarsi ad un sereno riposo attraverso un arredo che è al tempo stesso scultura e rifugio.

Bed designed by Draw Studio

The harmony of contrasts defines Moon, a bed transforming sleep into a complete wellness experience. An island of softness seamlessly erasing gravity with its large, generous shapes, deep headboard and ultra-soft sommier framed by marble flanks wrapping the bed like a protective frame. The authentic and sensorial materials of marble and leather are a crucial part of this experience where the eternal firmness versus the warm surfaces invite you to fully abandon yourself to be swept into a world of serenity, all through a furnishing item that is both a sculpture and a heavenly retreat.

Moon

MOQB001 Moon Letto 228x260x84
Moon bed 228x260x84

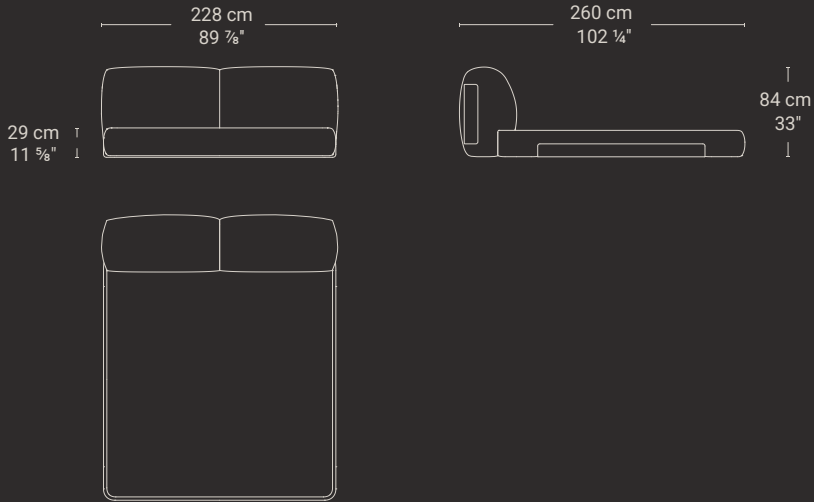

MOQB002 Moon Letto 208x260x84
Moon bed 208x260x84

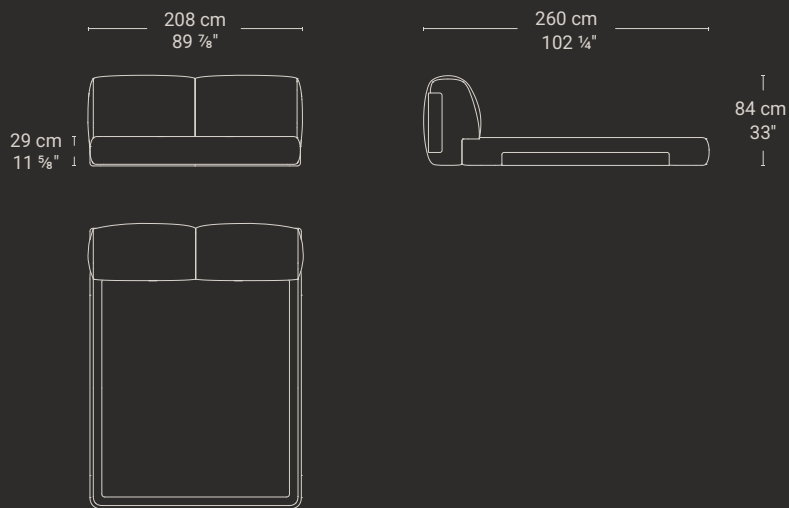

Adym

design by Gabriele e Oscar Buratti

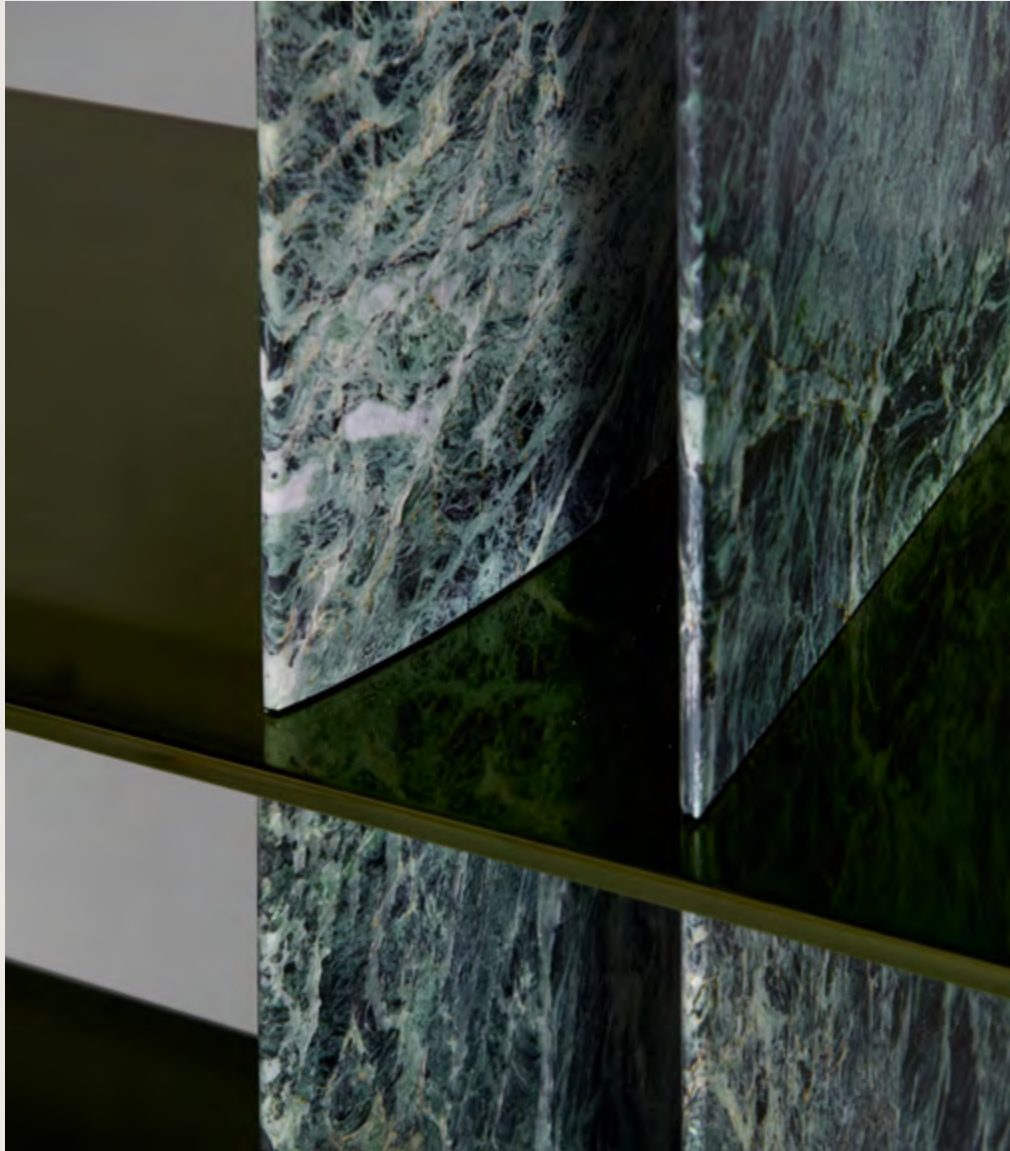

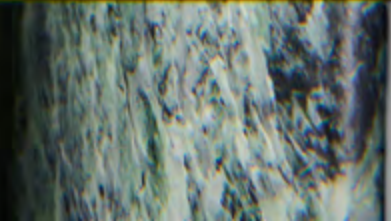
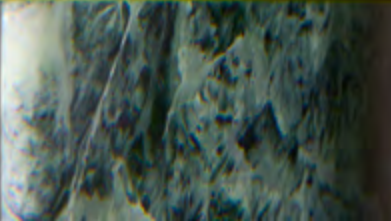
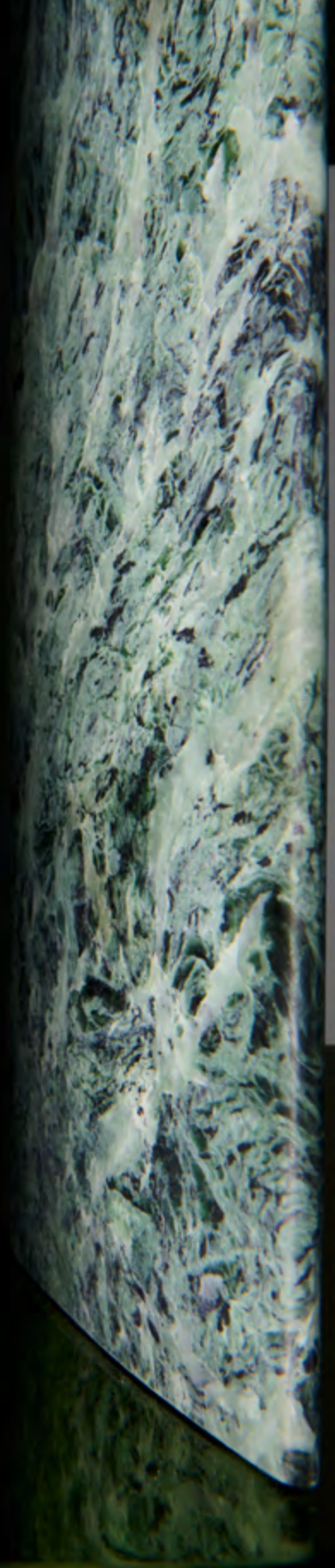



ADYM Libreria 6 ripiani / Bookshelf 6 shelves
Marmo Verde Alpi, metallo verde lucido / Verde Alpi
marble, Green Glossy Metal

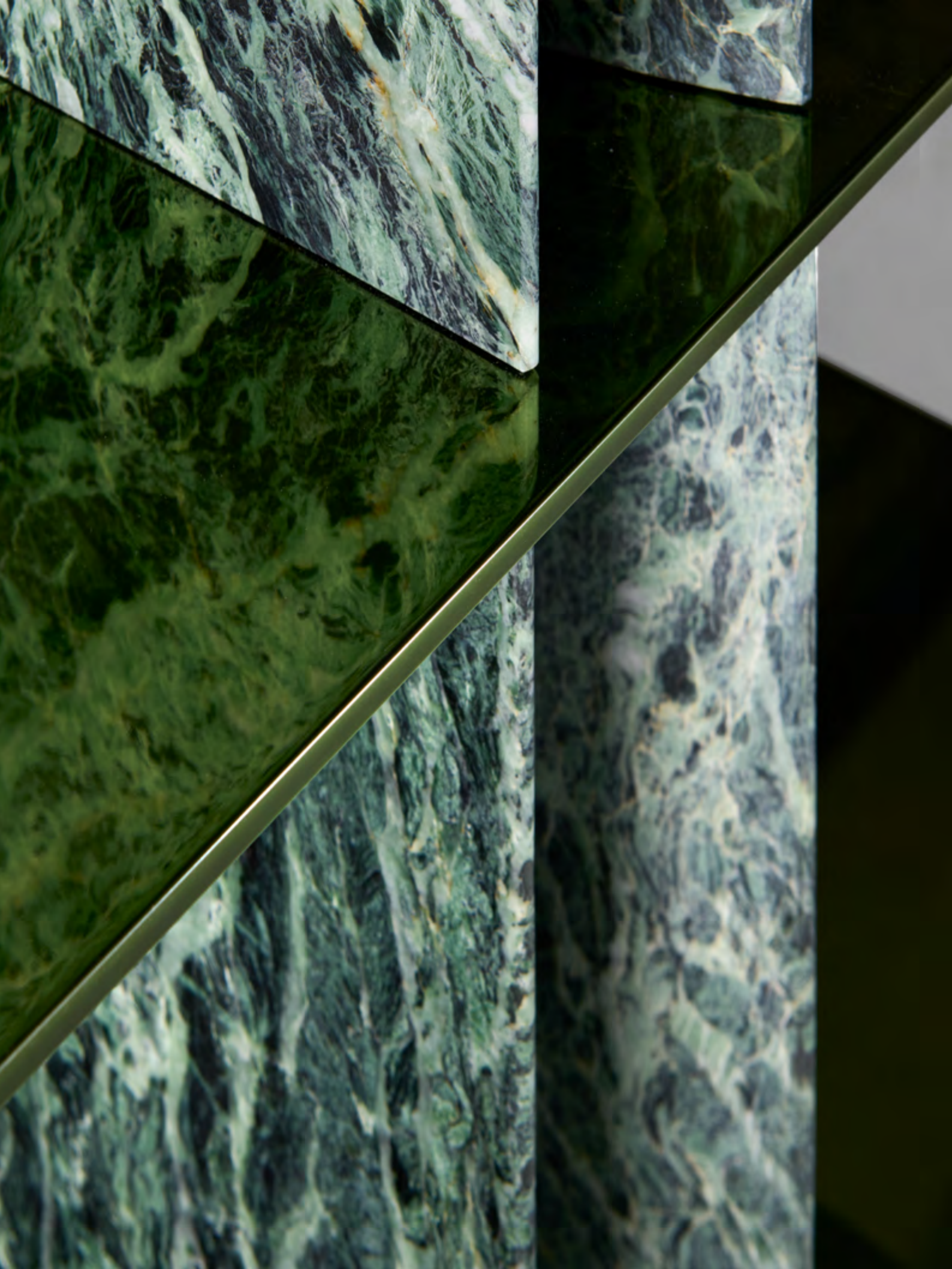



ADYM Libreria 3 ripiani / Bookshelf 3 shelves
Marmo Verde Alpi, Metallo verde lucido / Verde Alpi
marble, Green Glossy Metal

Adym

Libreria, design by Gabriele e Oscar Buratti

La libreria ADYM, anch'essa presentata in Verde Alpi, è un arredo dalla spiccata flessibilità. Contraddistinto da un sistema di sottili piani in metallo, sostenuti dalle doppie basi in marmo, può essere composto con estrema libertà per creare soluzioni di differenti livelli e organizzare gli spazi in maniera diversa e articolata. Ideale a parete, così come a centro stanza.

Le possibilità compositive prevedono di fare basi a due piani, console a tre piani, librerie a quattro, cinque o più piani.

Bookshelf designed by Gabriele and Oscar Buratti

The ADYM bookshelf, in Verde Alpi marble, is a versatile furnishing. It features slim metal shelves supported by dual marble bases, allowing for limitless configurations that can create spaces across multiple levels.

Whether against a wall or as a room's central point, the bookshelf's design options range from two-shelf bases to multi-tiered structures, accommodating four, five, or more shelves.

Adym

ADYL002 Adym Libreria 200x40x182 - 6 ripiani
Adym Bookshelf 200x40x182 - 6 shelves

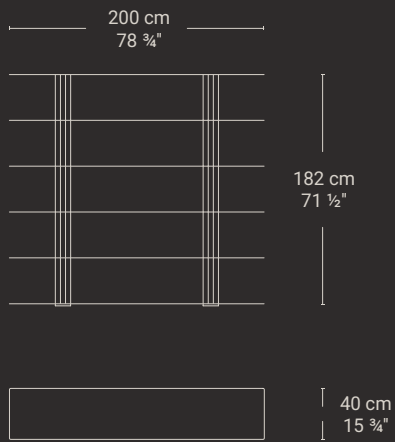

ADYL003 Adym Libreria 200x40x74 - 3 ripiani
Adym Bookshelf 200x40x74 - 3 shelves

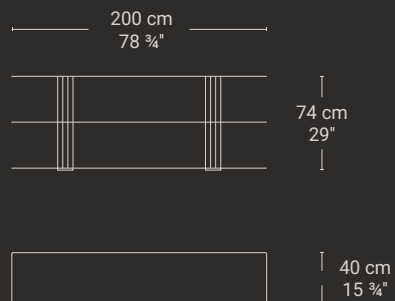

ADYL004 Adym Libreria 200x40x37 - 2 ripiani
Adym Bookshelf 200x40x37 - 2 shelves

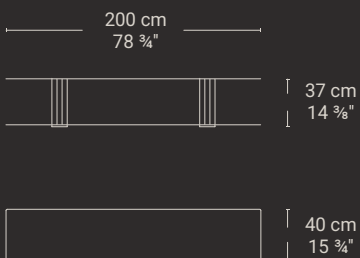

Pagina

design by Migliore+Servetto







PAGINA Libreria 4 moduli / Bookshelf 4 modules
Marmo Portoro Nero, calamina
Portoro Nero marble, Calamina





PAGINA Libreria 1 modulo / Bookshelf 1 module
Marmo Breccia Antica, metallo nuvolato opaco
Silver / Breccia Antica marble, Matt Cloudy
Silver Metal



Pagina

Libreria, design by Migliore + Servetto

Come un grande libro aperto, le cui pagine si dispiegano per accogliere e riflettere la luce. Pagina è una libreria modulare che gioca sul ritmo e sull'alternanza di materiali. Il susseguirsi sfalsato di elementi in marmo e metallo, unito al movimento dei piani sagomati (con profondità minima 31 cm e massima 41 cm) genera una dinamicità mutevole, amplificata dall'interazione con il fondale. Pagina riempie lo spazio con leggerezza e trasforma la percezione dell'ambiente grazie a un continuo gioco luci, ombre e profondità. La libreria prende forma da due moduli base (con lunghezza 73 cm e 113 cm e altezza 40.7 cm) che possono essere combinati tra loro per ottenere differenti configurazioni.

Bookshelf designed by Migliore + Servetto

Like a large open book with pages unfolding to receive and reflect light, Pagina is a modular bookshelf that plays with the rhythm and use of alternative materials. The staggered succession of marble and metal elements, combined with the movement of the shaped shelves, with a minimum depth of 31 cm and maximum depth of 41 cm, generates a fluid and varying rhythm that is emphasized by the dialogue with its backdrop. A piece that fills space with lightness, Pagina transforms one's perception of the environment with its continuous play on reflection and depth. The library is built with two basic modules, with a respective length of 73 cm and 113 cm and height of 40.7 cm, that can together be combined differently to obtain varied configurations.

Pagina

- PAGC001 Pagina Libreria 1 modulo 117x41x255 Calamina
Pagina Bookshelf 1 module 117x41x255 Calamina
- PAGC006 Pagina Libreria 1 modulo 117x41x255 Lucido
Pagina Bookshelf 1 module 117x41x255 Glossy
- PAGC016 Pagina Libreria 1 modulo 117x41x255 Nuvolato Opaco Gold / Silver
Pagina Bookshelf 1 module 117x41x255 Matt Cloudy Gold / Silver

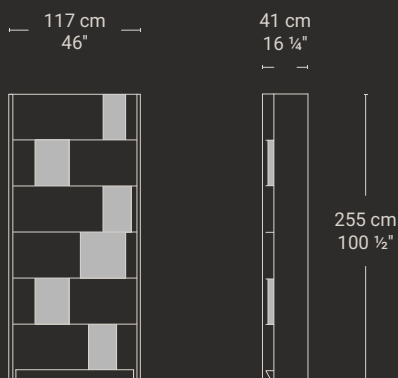

- PAGC005 Pagina Libreria 1 modulo 73x41x255 Calamina
Pagina Bookshelf 1 module 73x41x255 Calamina
- PAGC007 Pagina Libreria 1 modulo 73x41x255 Lucido
Pagina Bookshelf 1 module 73x41x255 Glossy
- PAGC017 Pagina Libreria 1 modulo 73x41x255 Nuvolato Opaco Gold / Silver
Pagina Bookshelf 1 module 73x41x255 Matt Cloudy Gold / Silver

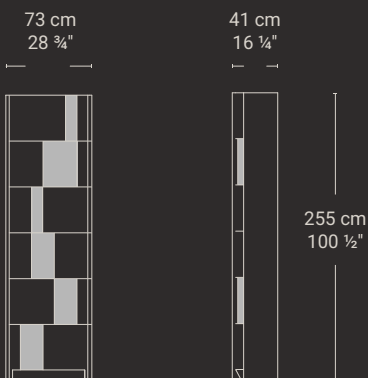

Pagina

- PAGC002 Pagina Libreria 3 moduli alta 264x41x255 Calamina
Pagina Bookshelf 3 modules high 264x41x255 Calamina
- PAGC008 Pagina Libreria 3 moduli alta 264x41x255 Lucido
Pagina Bookshelf 3 modules high 264x41x255 Glossy
- PAGC018 Pagina Libreria 3 moduli alta 264x41x255 Nuvolato Opaco Gold / Silver
Pagina Bookshelf 3 modules high 264x41x255 Matt Cloudy Gold / Silver

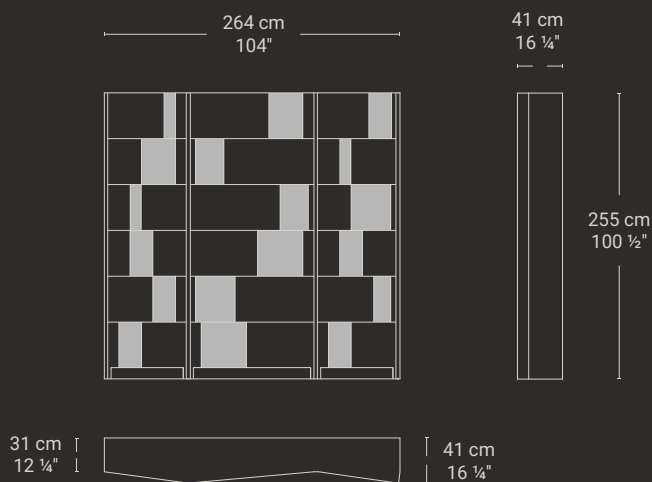

- PAGC003 Pagina Libreria 3 moduli bassa 344x41x153 Calamina
Pagina Bookshelf 3 modules low 344x41x153 Calamina
- PAGC009 Pagina Libreria 3 moduli bassa 344x41x153 Lucido
Pagina Bookshelf 3 modules low 344x41x153 Glossy
- PAGC018 Pagina Libreria 3 moduli bassa 344x41x153 Nuvolato Opaco Gold / Silver
Pagina Bookshelf 3 modules low 344x41x153 Matt Cloudy Gold / Silver

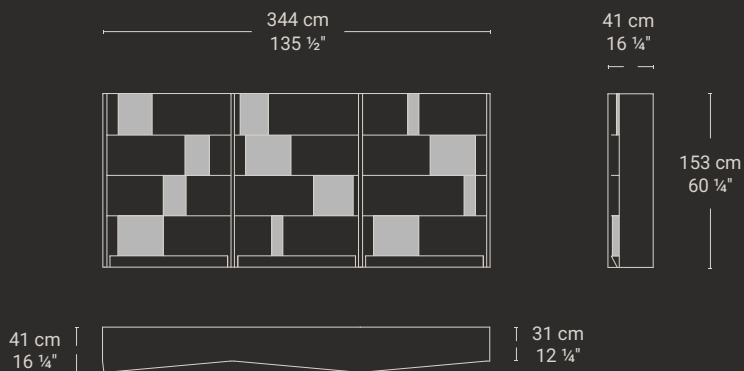

Pagina

- PAGC004 Pagina Libreria 4 moduli 337x41x153 Calamina
Pagina Bookshelf 4 modules 337x41x153 Calamina
- PAGC010 Pagina Libreria 4 moduli 337x41x153 Lucido
Pagina Bookshelf 4 modules 337x41x153 Glossy
- PAGC019 Pagina Libreria 4 moduli 337x41x153 Nuvolato Opaco Gold / Silver
Pagina Bookshelf 4 modules 337x41x153 Matt Cloudy Gold / Silver

specifiche prodotto/
product specifications

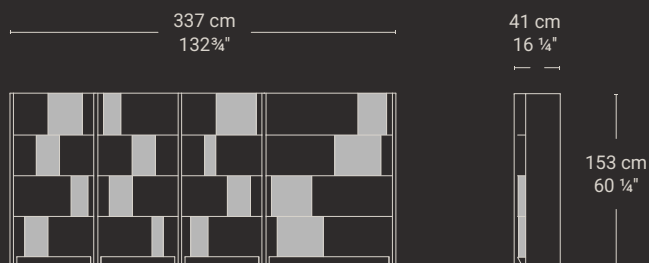

Artemisia

design by Stefano Gallizioli





Artemisia



Artemisia



ARTEMISIA Sedia da pranzo / Dining chair
Pelle naturale Skin, Frassino naturale spazzolato / Skin
Natural Leather, Natural Brushed Ash

Artemisia

Seduta, design by Stefano Gallizioli

Artemisia è un incontro tra dolcezza e vigore, un'interpretazione moderna del coraggio e della determinazione. La sua silhouette, che richiama linee curve e femminili, racchiude un'anima forte - come quella della leggendaria comandante Artemisia, unica donna a guidare la flotta di Serse, a cui la collezione deve il nome. Le forme avvolgenti della seduta invitano al relax - enfatizzate dal rivestimento in pelliccia di Capra e Montone Rasato - ma è nelle linee decise della struttura che si esprime la sua personalità: una struttura solida in legno, che trasmette sicurezza e resistenza.

La sedia e la poltroncina Artemisia sono oggetti da vivere nel loro appeal ispirazionale, in grado di adattarsi a ogni ambiente con la loro eleganza senza tempo. Ogni dettaglio, ogni curva, racconta una storia di potere silenzioso e bellezza intrinseca, in un dialogo tra la delicatezza e l'energia, che rende questa seduta un pezzo unico, tanto nel design quanto nel significato.

Chair designed by Stefano Gallizioli

An encounter between strength and softness, Artemisia is a modern interpretation of courage and determination. Its silhouette of curved, feminine lines encapsulates a strong soul just like that of Artemisia, legendary commander and only woman to have lead Xerxes' fleet, whom the collection is named after. With its enveloping shape, sheepskin and fur, the seat invites you to relax but its personality is expressed in the strong structural lines: a solid wooden frame conveying security and strength.

The Artemisia chair and armchair, with their ability to adapt in any environment, are inspirational items to experience and timelessly elegant. Every detail and curve tells a story of silent power and intrinsic beauty in a dialogue between delicacy and energy, making the Artemisia chair not only unique in its design but in its meaningfulness.

Artemisia

ARTD001 Artemisia Sedia 71x65x77 Frassino Spazzolato Nero
Artemisia Chair 71x65x77 Black Brushed Ash

ARTD002 Artemisia Sedia 71x65x77 Frassino Spazzolato Naturale
Artemisia Chair 71x65x77 Natural Brushed Ash

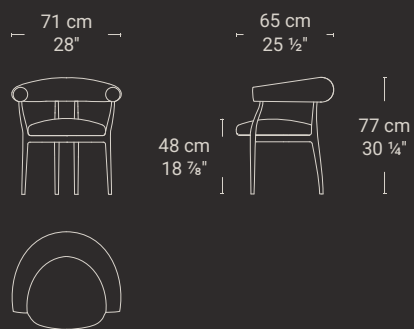

Birky

design by Gabriele e Oscar Buratti





Birky



BIRKY Sedia da pranzo con braccioli /
Dining chair with armrests
Tessuto Seishun marrone, metallo marrone lucido
Seishun Fabric Brown, Brown Glossy Metal



BIRKY Sedia da pranzo /
Dining chair

Birky

Seduta, design by Gabriele e Oscar Buratti

Femminilità, grazia, eleganza rivivono nella famiglia di sedute Birky, una poltroncina discreta nella sua raffinatezza, delicata nel design e nell'appeal. Sia nella versione con braccioli che senza, la sedia Birky arreda donando comfort e relax, sia nelle cornici più formali dedicate al workspace quanto nei più familiari contesti dove regna la convivialità. Le sue linee morbide e le rotondità dell'imbottitura (rivestita in pelle o tessuto) accolgono in un abbraccio avvolgente, sostenute da esili gambe in metallo che donano ulteriore slancio alla seduta. Ogni dettaglio è studiato per trasmetterne il carattere: dalla sciancratura dello schienale che evoca la bellezza di una schiena femminile, all'inserimento della cerniera a vista che attinge dal mondo della moda e della pelletteria, esaltando la geometria del sedile e dello schienale.

Chair designed by Gabriele e Oscar Buratti

Femininity, grace and elegance come alive in the Birky chair family, discreet in its refinement, delicate in its design and appeal. In both versions with and without armrests, Birky provides comfort and relaxation in formal workspace settings as well as in more familiar environments where conviviality reigns. The soft lines and roundness of its padding (upholstered in leather or fabric) welcome you in an enveloping embrace, whilst the slender metal legs add gracious momentum to the seat. Every detail is designed to convey Birky's character: from the curved back evoking the beauty of a feminine back, to the visible zip that recalls the world of fashion and leather goods, enhancing the geometry of the seat and back.

Birky

BIRC001 Birky Sedia da pranzo 50x56x80
Birky Dining chair 50x56x80

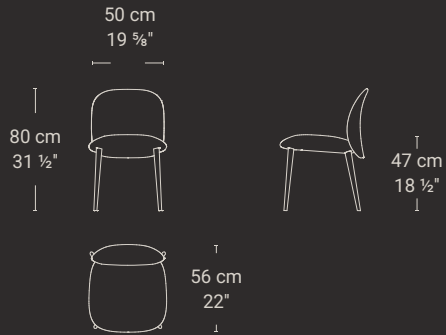

BIRC002 Birky Sedia da pranzo con braccioli 58x56x80
Birky Dining chair with armrests 58x56x80

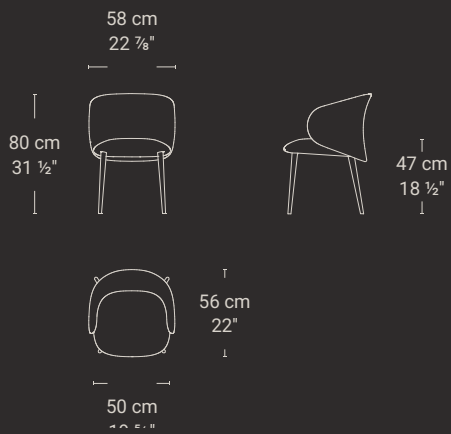

Cavo

design by Migliore+Servetto



Cavo



Cavo

Specchiera, design by Migliore+Servetto

La specchiera CAVO è caratterizzata da un grande disco di luce impreziosito da una calotta emisferica in rame bronzato che ospita la principale sorgente luminosa, a illuminare di luce riflessa il volto.

Un involucro in metallo verniciato con effetto rame sfumato riveste l'intera struttura e ne segna la profondità, richiamando una forma conica.

Una strip led posta sul retro della specchiera amplifica e diffonde l'angolo di luce.

Mirror designed by Migliore+Servetto

The CAVO mirror features a large light disc complemented by a bronzed copper semi-sphere cap, which encloses the primary light source. This casts a reflective glow onto the face.

A painted metal casing with a shaded copper finish covers the structure and enhances its depth, recalling a conical shape.

A LED strip positioned at the back of the mirror broadens and diffuses the light angle.

CAVS001 Cavo Specchiera D175x21
Cavo Mirror D175x21

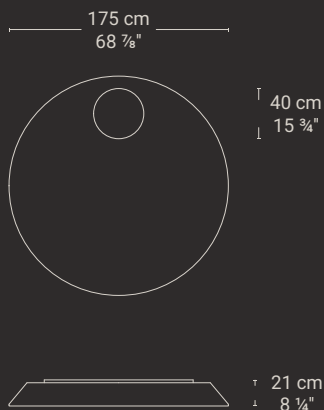

Dima

design by Migliore+Servetto







Dima

Specchiera, design by Migliore+Servetto

DIMA è una specchiera in metallo di forma rettangolare che, con la sua preziosa cornice dal sapore geometrico, gioca sull'alternanza di vuoti e pieni, presentandosi come un oggetto che si sviluppa su molteplici livelli di profondità. Alcuni inserti in marmo di recupero – in numero differente (dai 3 ai 7) e dalle dimensioni variabili - arricchiscono la cornice e, bagnati da una luce radente, accentuano ancora di più la tridimensionalità della specchiera.

Mirror designed by Migliore+Servetto

DIMA is a rectangular metal mirror with a sophisticated geometric frame which uses the alternation of full and empty spaces, as an object that evolves on multiple levels of depth. Reclaimed marble inserts of different sizes (ranging from three to seven) are illuminated by a grazing light, enhance the frame and emphasise the mirror's three-dimensional appearance.

DIMS001 Dima Specchiera 200x15x80
Dima Mirror 200x15x80

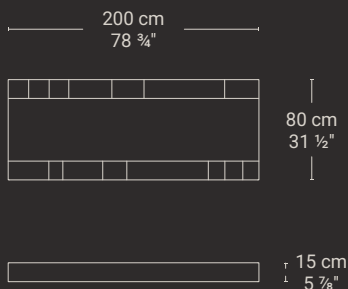

Micelio

design by atelier oï





Micelio



MICELIO Seduta doppia bassa / Double Seat low
Marmo Valentine Grey, Tessuto Alpaca grigio
Valentine Grey marble, Alpaca Fabric grey





MICELIO Seduta doppia alta / Double Seat high

Micelio

Sistema di sedute modulare, design by atelier oï

Micelio è un elemento vivo, in costante evoluzione. Cresce e si trasforma nello spazio. Nato dal concept che ha dato forma dall'omonima collezione di coffee table, questo sistema di sedute modulare si ispira alla natura invisibile delle catene miceliali, esplorando così il tema della connessione e del fluire delle forme. La natura organica della base si presta a configurazioni infinite, e accoglie le poltrone girevoli in pelle che ne amplificano il senso di movimento e fluidità. La rotazione delle morbide sedute, che possono vivere singolarmente o in coppia, creano un andamento ritmato, un'interazione spontanea tra corpi e spazio.

Modular seating system designed by atelier oï

Micelio is an ever-evolving living element that grows and transforms within spaces. Born from the concept of its namesake coffee table collection, this modular seating system is inspired by the invisible nature of mycelial chains, exploring the theme of connection and the flow of forms. Infinite configurations become possible thanks to the organic nature of the base, with leather swivel chairs emphasizing the sense of movement and fluidity. The rotation of the soft seats, which can live individually or in pairs, creates a spontaneous interaction between the body and space in a rhythmic pattern.

Micelio

MICC006 Micelio Seduta singola 167x70x73
Micelio Seat single 167x70x73

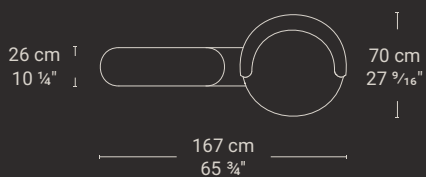

MICC007 Micelio Seduta doppia bassa 249x70x73
Micelio Seat double low 249x70x73

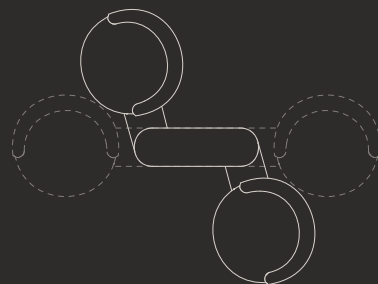
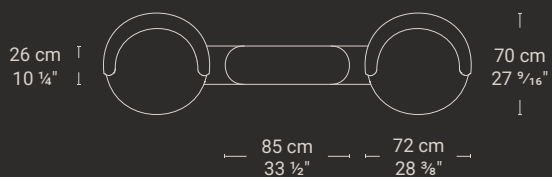
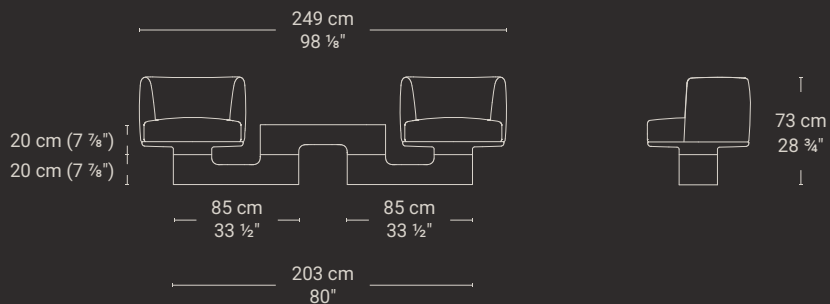

Micelio

MICC008 Micelio Seduta doppia alta 249x70x73
Micelio Seat double high 249x70x73

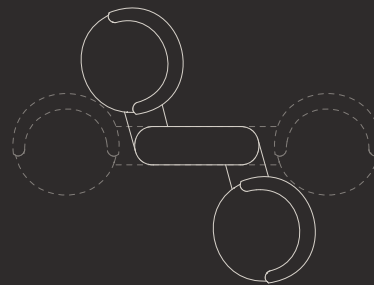
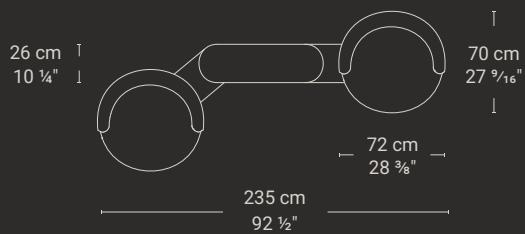
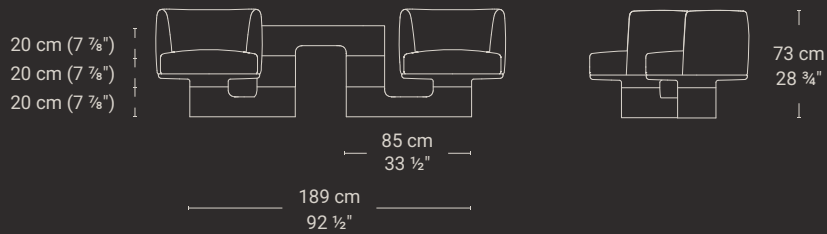

specifiche prodotto/
product specifications

Branch

design by Zaha Hadid Architects





Branch



BRANCH Marmo Bianco Carrara Statuarietto /
Bianco Carrara Statuarietto marble



Branch

Console, design by Zaha Hadid Architects

In equilibrio tra leggerezza e solidità, la console Branch appare contemporaneamente sospesa e saldamente ancorata a terra in una costante tensione tra forze opposte. Ricavata da un unico pezzo di marmo, la console nasce da due rami che si sviluppano in modo simmetrico collegando senza soluzione di continuità la base e il piano superiore. Un grande vuoto al centro sfida la solidità del materiale e ne alleggerisce il disegno. Le dimensioni del piano proposto sono 290x68 cm.

Console designed by Zaha Hadid Architects

Balanced between lightness and stability, the Branch console appears simultaneously suspended yet firmly grounded by the opposing forces acting upon it. Carved from a single piece of marble, two symmetrical branches seamlessly connect the console's base and top. A large central void defies the solidity of its robust material and enhances the ethereal qualities of the design. The surface of the console's top spans 290x68 cm.

BRAC001 Branch Console 290x68x73

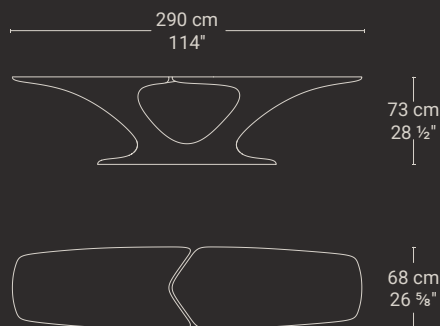

La collezione Branch è disponibile su richiesta in diversi marmi, previa verifica tecnica.
The Branch collection is available on request in different marbles, after technical testing.

Piega

design by Migliore+Servetto









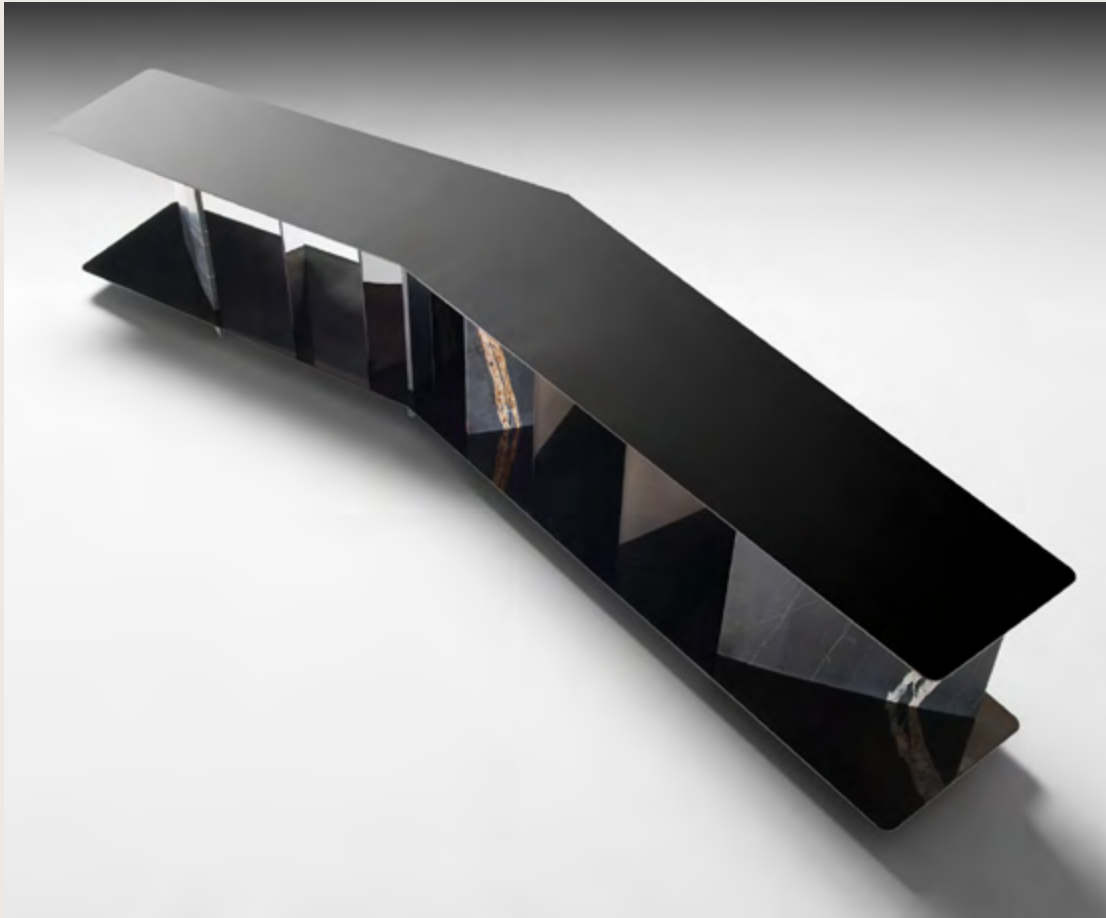

PIEGA Console sagomata / Shaped console
Marmo Sahara Noir, metallo nero lucido / Sahara Noir marble,
Black Glossy Metal

Piega

Console, design by Migliore + Servetto

Crea un paesaggio tridimensionale la console Piega, che deve il suo nome al calibrato gioco di asimmetrie che la definisce - dall'apertura inclinata degli elementi divisorii fino alla pianta irregolare. Ne deriva una composizione di pieni e vuoti, di luce e ombra, in cui le partiture si dispongono come quinte materiche pronte ad accogliere una varietà di oggetti eterogenei. Realizzata in marmo e metallo verniciato, Piega si colloca liberamente nello spazio, sia a parete sia come elemento di separazione a centro stanza: una presenza architettonica capace di dialogare sempre con l'ambiente circostante.

Console designed by Migliore + Servetto

Defined by its calibrated play on asymmetries, the Piega sideboard creates a three-dimensional landscape - from the slanting position of the dividing elements to the irregular surface. Resulting in a composition of solids and voids, light and shadows, partitions are like a backdrop ready to welcome a variety of items. Made of marble and painted metal, Piega stands freely, be it against a wall or centrally as a dividing element; an architectural object befitting any room.

Piega

PIEC001 Piega Console sagomata 302x79x56 Spazzolato
Piega Shaped Console 302x79x56 Brushed

PIEC003 Piega Console sagomata 302x79x56 Lucido
Piega Shaped Console 302x79x56 Glossy

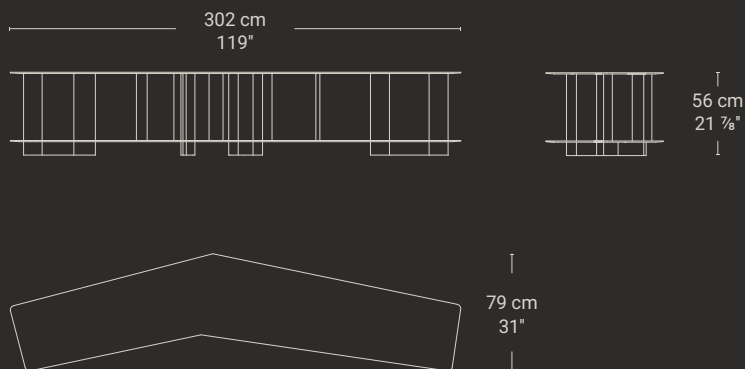

PIEC002 Piega Console lineare 302x40x56 Spazzolato
Piega Linear Console 302x40x56 Brushed

PIEC004 Piega Console lineare 302x40x56 Lucido
Piega Linear Console 302x40x56 Glossy

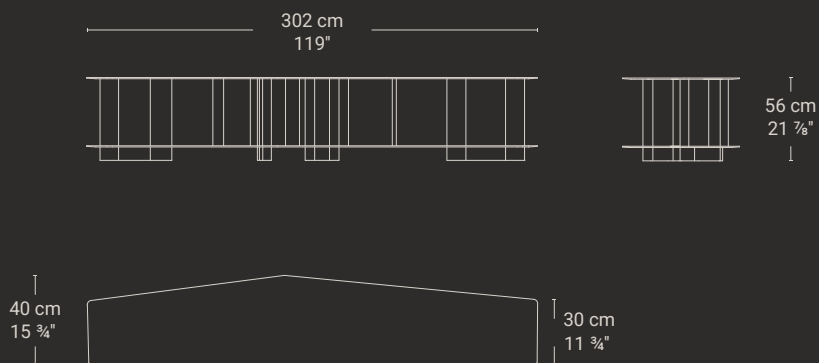

Coronae

design by Migliore+Servetto





Coronae



CORONAE D130x38 Coffee Table Base Marmo /
Coffee Table Marble Base
Marmo Portoro Nero / Portoro Nero marble





CORONAE D60x42, CORONAE D90x47
Coffee Table Base Metallo / Coffee Table Metal Base
Marmo Sahara Noir, metallo nero lucido / Sahara Noir
marble, Black Glossy Metal

Coronae

Coffee tables, design by Migliore + Servetto

L'essenza dell'elegante semplicità rivive nei coffee table Coronae. L'azienda esplora il concetto di minimalismo organico attraverso forme equilibrate e pulite unite a dettagli originali applicati al marmo. A connotare infatti questi complementi è la lavorazione del piano, realizzato con un bordo inclinato e asimmetrico, così da conferire un effetto di dinamicità e movimento, soprattutto in combinazioni multiple che affiancano le differenti misure disponibili (con diametro 60, 90, 130 cm) L'asimmetria è poi ripresa nella base, a tronco di cono che culmina in un cilindro. Coronae è quindi un oggetto estremamente sofisticato nella sua essenzialità.

Coffee tables designed by Migliore + Servetto

The essence of elegance in its simplicity is brought back to life with the Coronae coffee tables. The company explores the concept of organic minimalism through balanced, clean shapes combined with original details applied to marble, characterizing the workmanship of the tabletop. Its slanting and asymmetrical edge gives a sense of dynamism and movement, even more so in the multiple combinations in the different sizes available (diameter 60, 90 and 130 cm). The asymmetry is recaptured in the base, a truncated conical shape culminating in a cylinder. Coronae is, without doubt, an extremely sophisticated item in its essence.

Coronae

- CORC001 Coronae Coffee Table Base Marmo D130x38
Coronae Coffee Table Marble Base D130x38
- CORC006 Coronae Coffee Table Base Metallo D130x38 Nuvolato Opaco Gold / Silver
Coronae Coffee Table Metal Base D130x38 Matt Cloudy Gold / Silver
- CORC008 Coronae Coffee Table Base Metallo D130x38 Lucido
Coronae Coffee Table Metal Base D130x38 Glossy

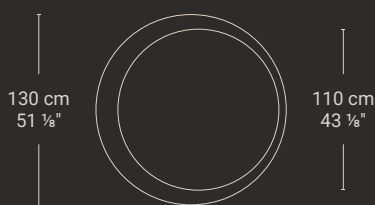
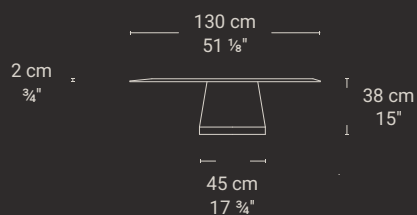

- CORC005 Coronae Coffee Table Base Marmo D90x47
Coronae Coffee Table Marble Base D90x47
- CORC004 Coronae Coffee Table Base Metallo D90x47 Nuvolato Opaco Gold / Silver
Coronae Coffee Table Metal Base D90x47 Matt Cloudy Gold / Silver
- CORC007 Coronae Coffee Table Base Metallo D90x47 Lucido
Coronae Coffee Table Metal Base D90x47 Glossy

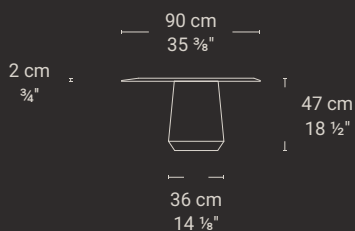

Coronae

- CORC002 Coronae Coffee Table Base Marmo D60x42
Coronae Coffee Table Marble Base D60x42
- CORC003 Coronae Coffee Table Base Metallo D60x42 Lucido
Coronae Coffee Table Metal Base D60x42 Glossy
- CORC009 Coronae Coffee Table Base Metallo D60x42 Nuvolato Opaco Gold / Silver
Coronae Coffee Table Metal Base D60x42 Matt Cloudy Gold / Silver

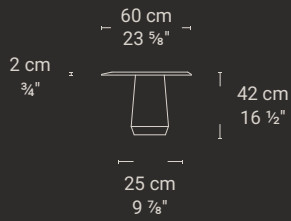

Delos

design by Draw Studio





Delos

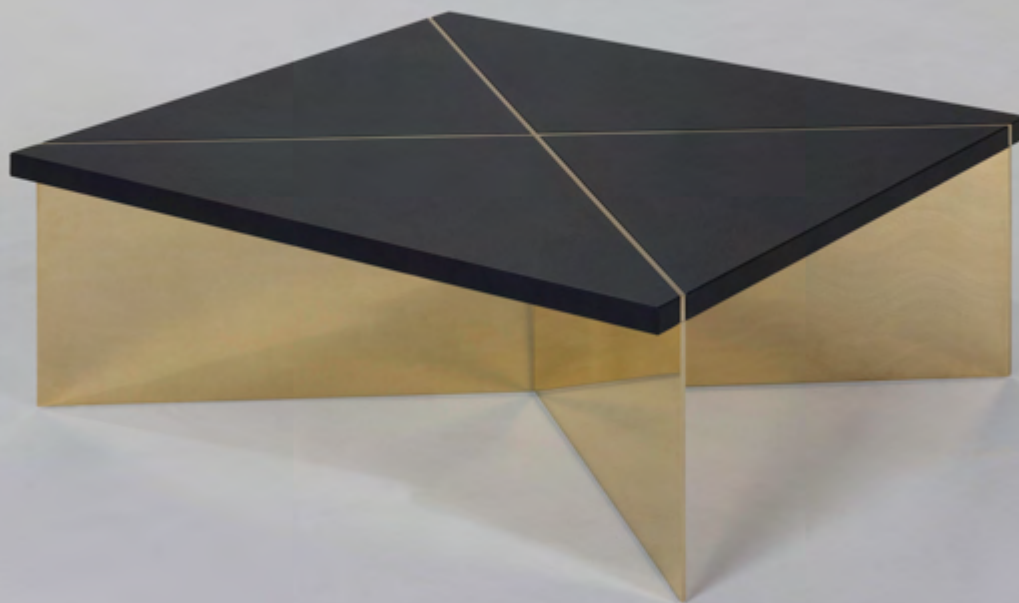

DELOS 100x100 Pelle naturale Vision nero, ottone lucidato /
Vision Natural Leather Black, Polished Brass

La collezione DELOS nasce dall'idea di creare una famiglia di coffee tables di varie forme e misure combinabili tra loro. L'ispirazione scaturisce dall'osservazione delle carte nautiche antiche, nelle quali una moltitudine di sottili rette convergenti solcavano i mari e le terre e servivano a facilitare le misurazioni dei naviganti. Come le carte nautiche infatti, anche i top della collezione sono attraversati da linee intersecanti che li dividono in settori, quasi fossero le tracce di piegatura su dei fogli per origami, o i motivi geometrici di grandi quadri astratti.

Queste linee sono in realtà la struttura stessa dei tavolini: fogli di pregiato metallo finemente lavorato che partendo da terra incontrano il marmo del top, per affiorare in superficie. Si creano così delle forme geometriche pulite, scandite da pieni e vuoti che, accostandosi tra loro, danno vita a figure via via più complesse.

Delos



DELOS 150x150 Pietra lavica, acciaio lucidato /
Lava Stone, Polished Steel

DELOS D75 Marmo Verde Antigua, acciaio lucidato /
Verde Antigua marble, Polished Steel

Delos



tavolini / small tables

DELOS 100x100 Pelle naturale Vision nero, ottone lucidato /
Vision Natural Leather Black, Polished Brass

DELOS 150x100 Marmo Cipollino Misto, ottone lucidato /
Cipollino Misto Marble, Polished Brass

The DELOS collection comes from the idea of crafting a versatile series of coffee tables, each distinct in shape and size, designed to be paired. Inspiration came from ancient maritime maps with multiple converging lines crossing the seas and lands to help navigators' measurements. In the same way the collection's surfaces are adorned with intersecting lines that divide them into sections, reminiscent of origami creases or the geometric motifs found in abstract art. These lines form the tables' structural essence, with slender sheets of metal rising from the base to merge with the marble top, revealing themselves on the surface. The result is a series of clean geometric forms, defined by an interplay of full and empty spaces, which combine to create complex and captivating figures.

Delos

Coffee tables, design by Draw Studio

DELOS è una collezione raffinata, che lambisce i confini con l'arte. Adotta il marmo e il metallo come materiali eletti, ma il rivestimento dei piani prevede anche la pelle o delle laccature su legno, a creare infinite combinazioni cromatiche e materiche.

Disponibili nella versione quadrata, nella versione rettangolare e nella versione tonda.

Coffee tables designed by Draw Studio

DELOS is an elegant collection that blurs the line between furniture and art. It features marble and metal as primary materials, with options for leather-covered or lacquered wooden tops, offering endless colour and material combinations.

The collection is available in square, rectangular and round versions.

Delos

DELT001 Delos Tavolino Basso 100x100x35
Delos Low table 100x100x35



DELT002 Delos Tavolino Basso 150x100x35
Delos Low table 150x100x35

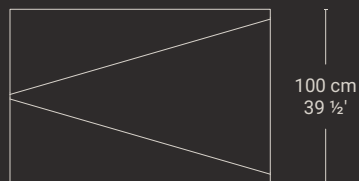

Delos

DELT003 Delos Tavolino Basso 150x150x25
Delos Low table 150x150x25

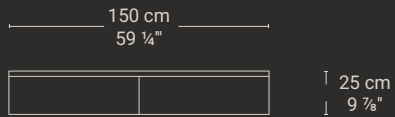

DELT004 Delos Tavolino Basso D75x45
Delos Low table D75x45



Leaf

design by Luca Martorano





Leaf



LEAF Coffee Table and table
Marmo Oyster White / Oyster White marble

Leaf

Coffee table, design by Luca Martorano

Leaf è un tavolo di design in pietra naturale nel quale la qualità della materia si eleva attraverso la leggerezza della forma. Un piano dallo spessore così sottile che sembra restare sospeso nell'aria come una foglia. Un esclusivo "gambo" in pietra naturale che dà energia alla struttura e all'ambiente. Un'opera unica di design, sintesi naturale fra estrema funzionalità e cura del dettaglio. Disponibile anche nella versione tavolo.

Coffee Table designed by Luca Martorano

Leaf is a natural stone designer table in which the quality of the material reaches its top, thanks to the light shape of the table. The top is so thin that seems to be suspended in the air, like a leaf. An exclusive natural stone "stem" gives energy to the structure and the environment. This is a unique piece of design, which is a natural combination of extreme functionality and attention to detail. Also available in the table version.

Leaf

LEAC004 Leaf Coffee Table D45x61

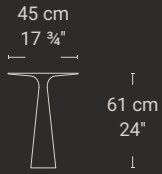

LEAC005 Leaf Coffee Table D57x51

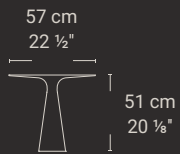

LEAC006 Leaf Coffee Table D70x39

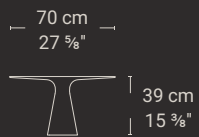

Micelio

design by atelier oï

tavolini/small tables







MICELIO Composizione 3 top / Composition 3 tops
Marmo Bianco Carrara Statuarietto / Bianco Carrara
Statuarietto marble



Micelio

Sistema componibile di tavoli bassi, design by atelier oi

Il sistema componibile di tavoli bassi Micelio è un progetto modulare che rivela un paesaggio organico e, nel nome, l'ispirazione all'apparato vegetativo dei funghi.

Caratterizzato da una forma unica nel suo genere, il progetto nasce dalla combinazione di due elementi scolpiti distinti che permettono di creare una serie infinita di forme diverse, connotando con dinamismo l'orizzonte domestico.

La lunghezza e la profondità delle composizioni sono variabili, per un'altezza di 42/63 cm.

All'insegna della versatilità, i piani del tavolino e gli elementi a ponte si combinano in un dinamico gioco per creare soluzioni di appoggio o di seduta, compatte o più allargate, per adattarsi alle esigenze più diverse sia in ambito domestico che hospitality.

Grazie alla sua forma sinuosa, la pietra naturale, valorizzata dalle irregolari venature che ne accentuano il fascino, arriva ad esprimere sensazioni di morbidezza in un elegante contrasto con la durezza della pietra.

Modular low table system designed by atelier oi

The modular low table system Micelio reveals an organic landscape and draws its name from the vegetative structure of mushrooms.

The design, distinguished by its unique form, combines two different sculpted elements that enable endless different shapes, dynamically defining the domestic horizon.

The compositions can vary in length and depth, with a height of 42/63 cm.

Embodying versatility, the table tops and the bridge elements interact dynamically to create compact or expanded support or seating solutions which adapt to different residential and hospitality needs.

With its flowing shape the natural stone is enhanced by the irregular veins that emphasise its charm. It expresses a sense of softness in stylish contrast with the stone's hardness.

Micelio

MICC004 Micelio Composizione 2 top
Micelio Composition 2 tops

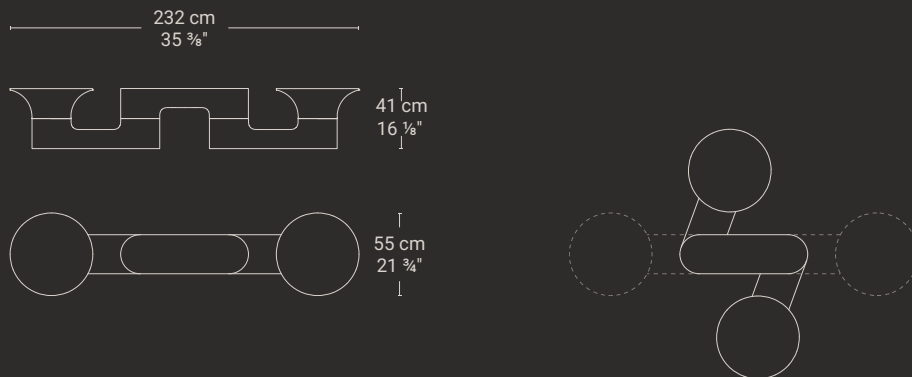

MICC005 Micelio Composizione 3 top
Micelio Composition 3 tops

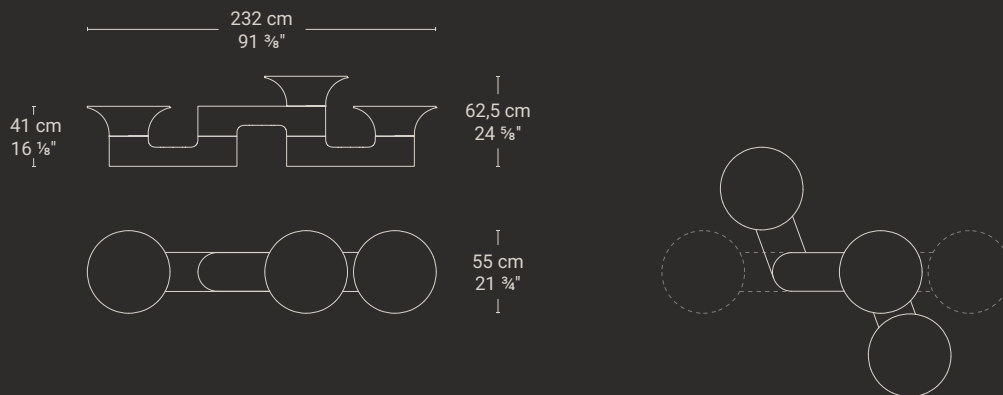

Theia

design by STUDIOPIVA





THEIA Coffee Table
Bronzo, Marmo Travertino Romano /
Bronze, Travertino Romano marble

Theia

Tavolini, design by STUDIOPIVA

La forma circolare del piano è l'elemento condiviso da tutti i modelli della serie Theia: tavoli, tavolini e sgabelli, che evocano nel nome l'omonimo pianeta che 4 miliardi di anni fa andò in collisione con la Terra (il cosiddetto "impatto gigante"), producendo la formazione del nostro unico satellite, la Luna. Questo evento galattico ed originario è rievocato dalle forme essenziali, quasi lunari, dei piani degli arredi Theia.

Tutti gli elementi della collezione, utilizzabili anche in contesti outdoor, sono caratterizzati da una struttura in fusione di bronzo costituita da un piano ad anello da cui si allungano le tre gambe (quattro nella versione tavolo da pranzo con diam. 180 cm); alla struttura, sagomata ad arte, aderiscono, quasi in simbiosi, gli inserti in marmo delle gambe e il piano - in marmo nel caso di tavoli e tavolini, rivestito in pelle Nabuk per gli sgabelli, disponibile in altre varianti di pelle o tessuto.

Coffee tables designed by STUDIOPIVA

The top circular shape is the element shared by all Theia range models. Tables, coffee tables and stools, with a name which evokes the planet that collided with the Earth four billion years ago (the "giant impact"), creating the Moon. This galactic and original event is suggested by the essential, almost lunar shapes of the tops of Theia furnishings.

The collection elements, which can be used outdoors, feature a cast bronze structure consisting of a ring-shaped top from which three legs (four in the dining table version with a 180 cm diameter) extend. The legs' marble inserts symbiotically adhere to the artfully shaped structure. The tables and coffee tables' top are in marble, the stools covered in Nabuk leather, and are available in other leather or fabric versions.

Theia

- THEC007 Theia Coffee Table D47x44 Bronzo
Theia Coffee Table D47x44 Bronze
- THEC008 Theia Coffee Table D47x44 Alluminio
Theia Coffee Table D47x44 Aluminium

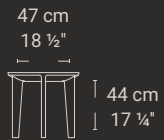

La Grande Muraglia

design by Mario Bellini





La Grande Muraglia

divani/sofas



LA GRANDE MURAGLIA

Divano tre posti / Three-seater sofa

Marmo Travertino Romano, Tessuto Alpaca / Travertino
Romano marble, Alpaca Fabric



La Grande Muraglia

Divani, design by Mario Bellini

EDIZIONE LIMITATA 50 PEZZI

La collezione è composta da un divano (a due o a tre posti) e da una poltrona, caratterizzati da una struttura in Travertino Romano (disponibile anche in altre varianti di marmo) che accoglie le avvolgenti imbottiture di sedute, braccioli e schienali. I montanti e il telaio si identificano con i pilastri e l'architrave di un immaginario edificio monumentale, in contrapposizione dialettica con gli elementi morbidi ed avvolgenti della seduta che accolgono il corpo come in un abbraccio.

La connotazione fortemente architettonica degli elementi di seduta non pregiudica in alcun modo il comfort e la flessibilità nell'uso. Bellini rilegge le forme scultoree di La Grande Muraglia disegnando oggi dei veri e propri modi di vivere le sedute in un'ottica contemporanea, pensando alla lettura, al riposo, alla meditazione.

Le sedute de La Grande Muraglia sono disponibili anche in versione outdoor.

Sofas designed by Mario Bellini

LIMITED EDITION 50 PIECES

The collection consists of a two- or three-seat sofa and an armchair, made of a Travertino Romano marble frame (available in other marble options). The structure houses the enveloping upholstery of the seats, armrests and backrests. The uprights and frame are identified with the pillars and architrave of an imaginary monumental building, in dialectical contrast with the seat's soft, enveloping elements that embrace the body.

The strongly architectural reference of the seats does not compromise comfort and flexibility. Bellini reinterprets La Grande Muraglia's sculptural forms, designing modern ways of experiencing seating for reading, resting, or meditating. The La Grande Muraglia seats are available in an outdoor variant.

specifiche prodotto/
product specifications

La Grande Muraglia

specifiche prodotto/
product specifications

LAD001

LGM Divano 3P 305x95x91
LGM Sofa 3S 305x95x91

EDIZIONE LIMITATA 50 PZ. / LIMITED EDITION 50 PCS.

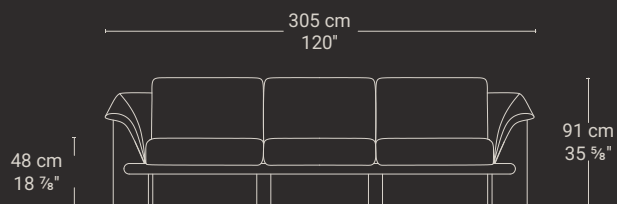

LAD002

LGM Divano 2P 224x95x91
LGM Sofa 2S 224x95x91

EDIZIONE LIMITATA 50 PZ. / LIMITED EDITION 50 PCS.

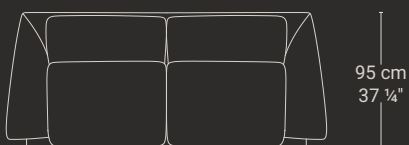
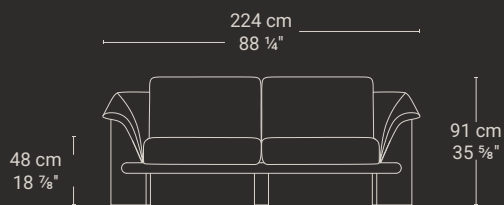

La Grande Muraglia

LAC004

LGM Chaise longue 225x120x95

EDIZIONE LIMITATA 50 PZ. / LIMITED EDITION 50 PCS.

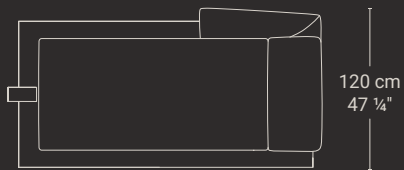
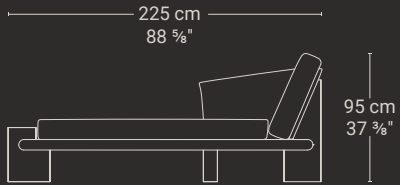

specifiche prodotto/
product specifications

Ordos

design by Stefano Gallizioli



Ordos



ORDOS Sofa con marmo / Sofa with marble
Tessuto Camargo nero, Marmo Sahara Noir, Bronzo patinato
opaco / Camargo Fabric Black, Sahara Noir marble, Matt
Patinated Bronze





ORDOS Dormeuse sinistra con marmo / Dormeuse left with marble
Pelle naturale Skin nero, Marmo Sahara Noir /
Skin Natural Leather Black, Sahara Noir marble



Ordos

Divano modulare, design by Stefano Gallizioli

Una distesa infinita di sabbia, dove la terra si fonde con il cielo. Ordos traduce questo panorama nel contesto dell'interior: una piattaforma fluttuante, sospesa tra la morbidezza delle cuscinate e la solidità del marmo. Con le sue ampie superfici orizzontali, il sistema di sedute modulare richiama la vastità infinita di un deserto, quello di Ordos in Mongolia a cui deve il nome, dove ogni forma si perde nell'orizzonte. L'ampia profondità di seduta, le texture di rivestimento (in tessuto o pelle), il basso schienale riportano alla mente quel paesaggio di colline ondulate e pianure. Un invito al relax e alla contemplazione.

Modular sofa designed by Stefano Gallizioli

An endless sand expanse where earth and sky merge. Ordos is the translation of this vision: a seemingly floating platform suspended between the softness of the cushion and the strength of the marble. With its large horizontal surfaces, the modular seating system recalls the uninterrupted vastness of the desert where all shapes get lost. Inspired by the Ordos desert in Mongolia, the ample depth of the seat, textured upholstery (fabric or leather) and low back are reminder of the landscape of undulating hills and plains and pure invitation to relax and reflect.

Ordos

ORSS001 Ordos Sofa con marmo 520x430x74
Ordos Sofa with marble 520x430x74

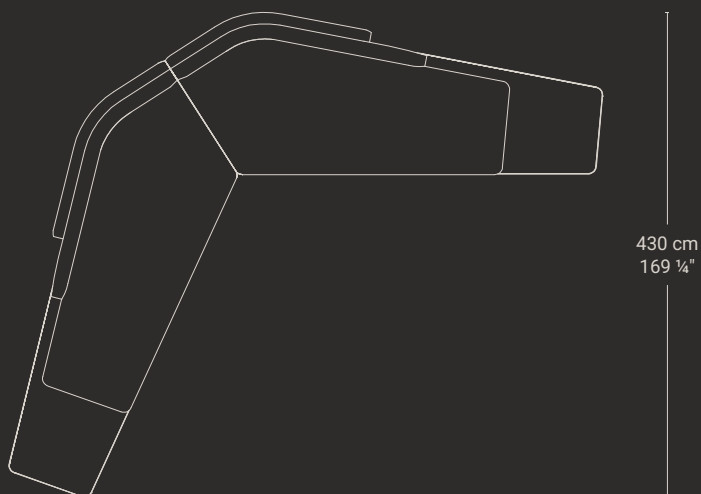

ORSS010 Ordos Sofa con braccioli di marmo 520x430x74
Ordos Sofa with marble armrests 520x430x74

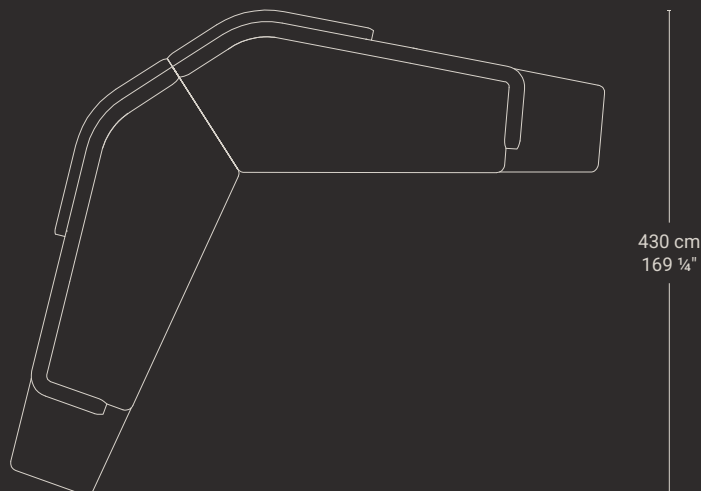

Ordos

ORSS011 Ordos Sofa con bracciolo di marmo sinistro 520x430x74
Ordos Sofa with marble armrest left 520x430x74

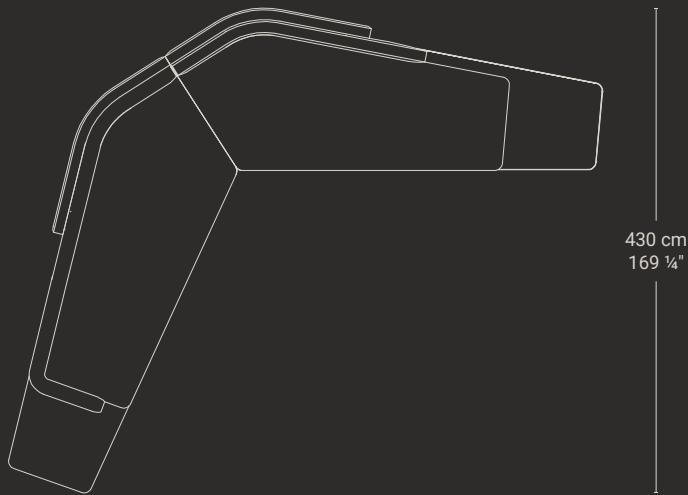

ORSS012 Ordos Sofa con bracciolo di marmo destro 520x430x74
Ordos Sofa with marble armrest right 520x430x74

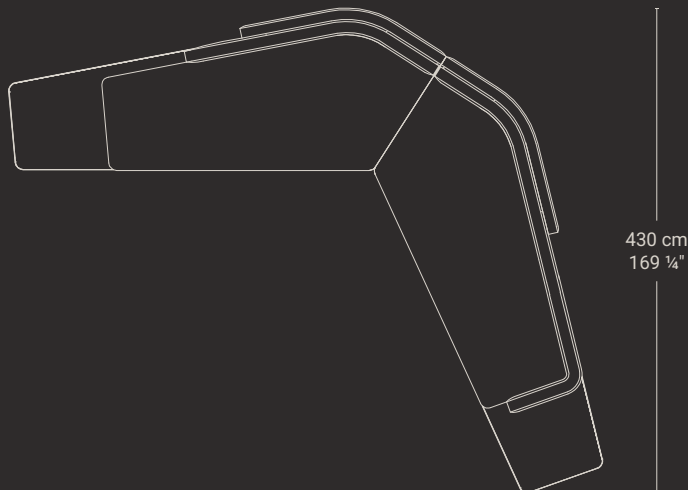

Ordos

ORSS019 Ordos Sofa con braccioli di marmo 520x430x74_da blocco
Ordos Sofa with marble armrests 520x430x74_solid

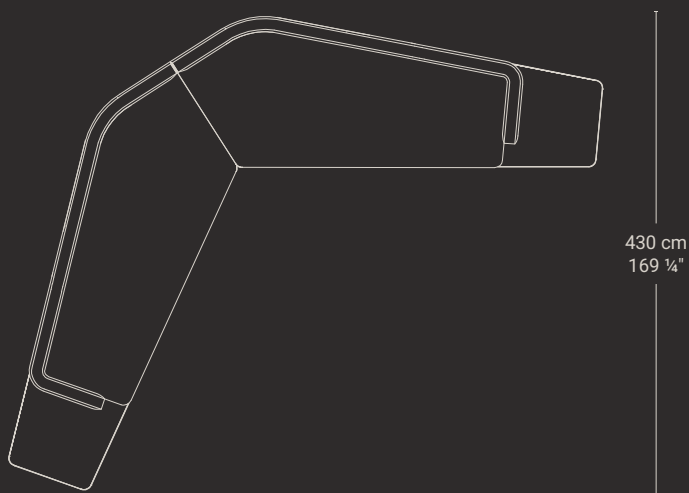

ORSS022 Ordos Sofa con marmo 520x430x74_da blocco
Ordos Sofa with marble 520x430x74_solid

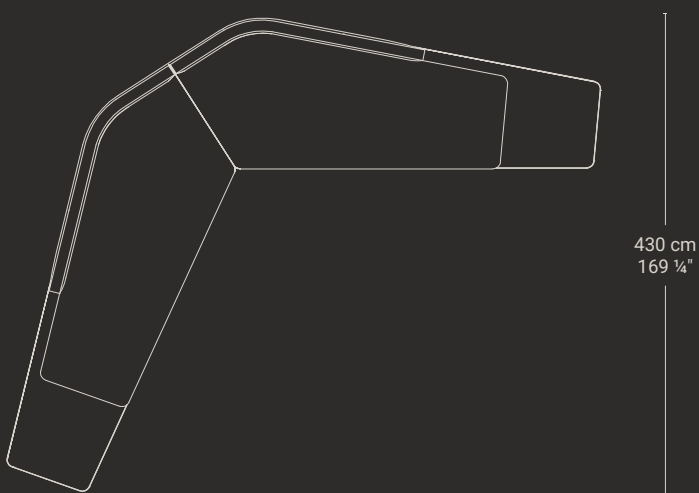
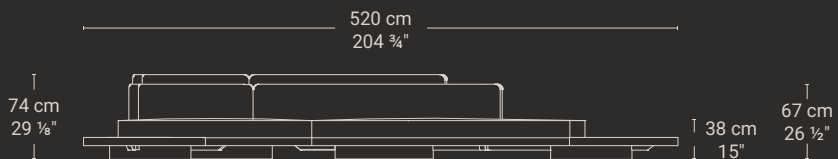

Ordos

ORSS020 Ordos Sofa con bracciolo di marmo sinistro 520x430x74_da blocco
Ordos Sofa with marble armrest left 520x430x74_solid

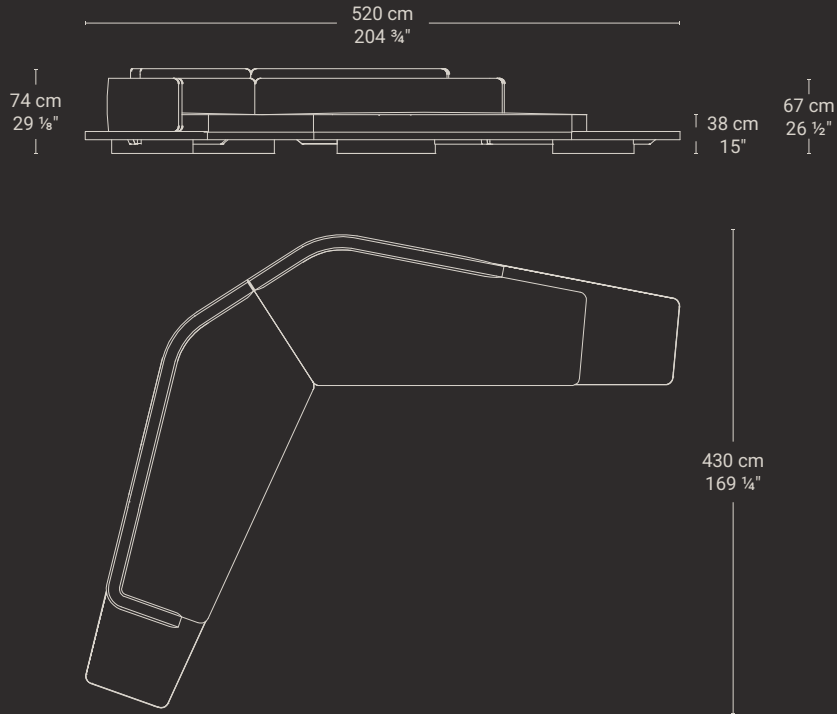

ORSS021 Ordos Sofa con bracciolo di marmo destro 520x430x74_da blocco
Ordos Sofa with marble armrest right 520x430x74_solid

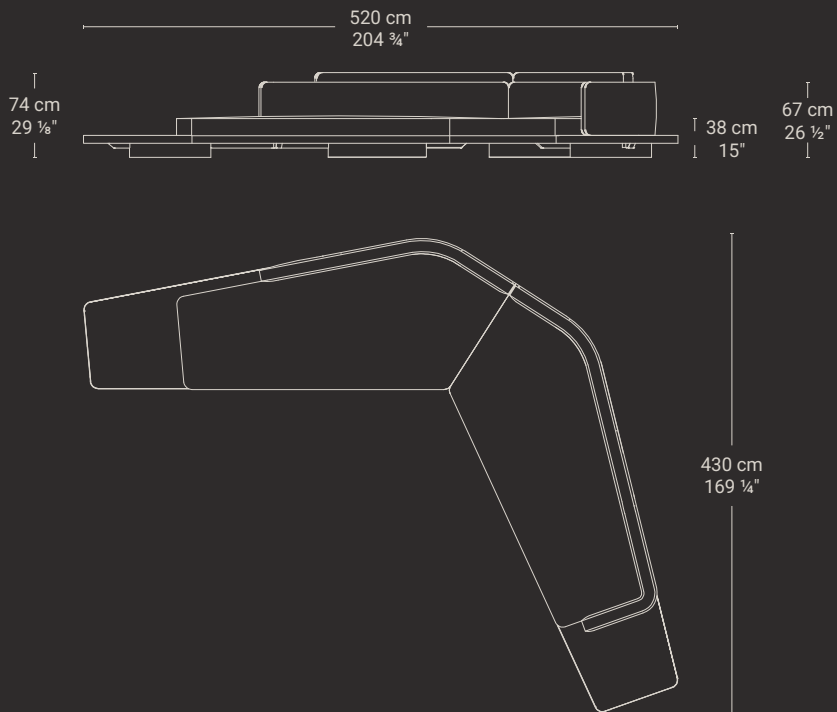

Ordos

ORSS008 Ordos Sofa con marmo 585x297x78
Ordos Sofa with marble 585x297x78

ORSS015 Ordos Sofa con marmo 585x297x78_da blocco
Ordos Sofa with marble 585x297x78_solid

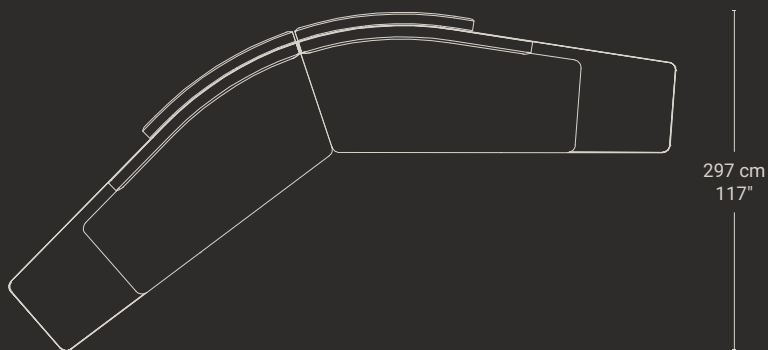
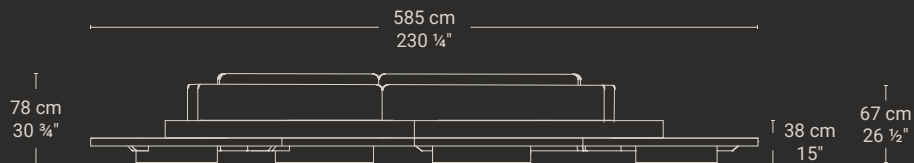

ORSS009 Ordos Sofa con braccioli di marmo 585x297x78
Ordos Sofa with marble armrests 585x297x78

ORSS016 Ordos Sofa con braccioli di marmo 585x297x78_da blocco
Ordos Sofa with marble armrests 585x297x78_solid

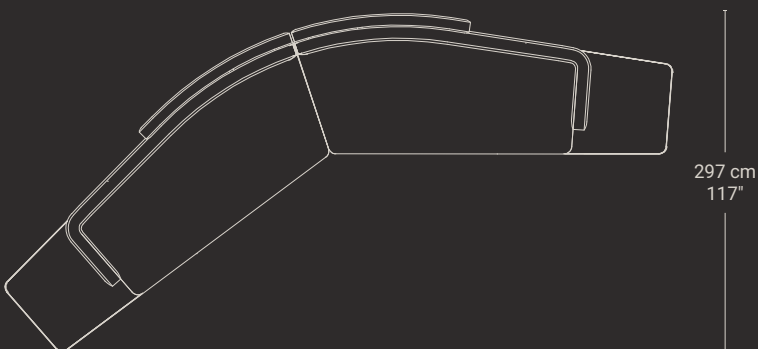
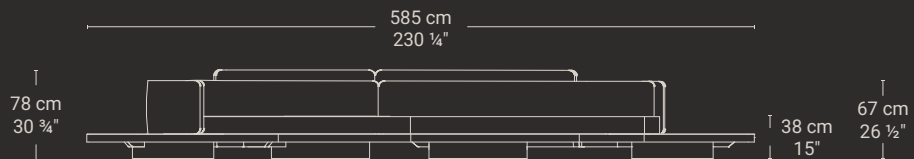

Ordos

ORSS013 Ordos Sofa con braccioli di marmo sinistro 585x297x78
Ordos Sofa with marble armrest left 585x297x78

ORSS018 Ordos Sofa con bracciolo di marmo sinistro 585x297x78_da blocco
Ordos Sofa with marble armrest left 585x297x78_solid

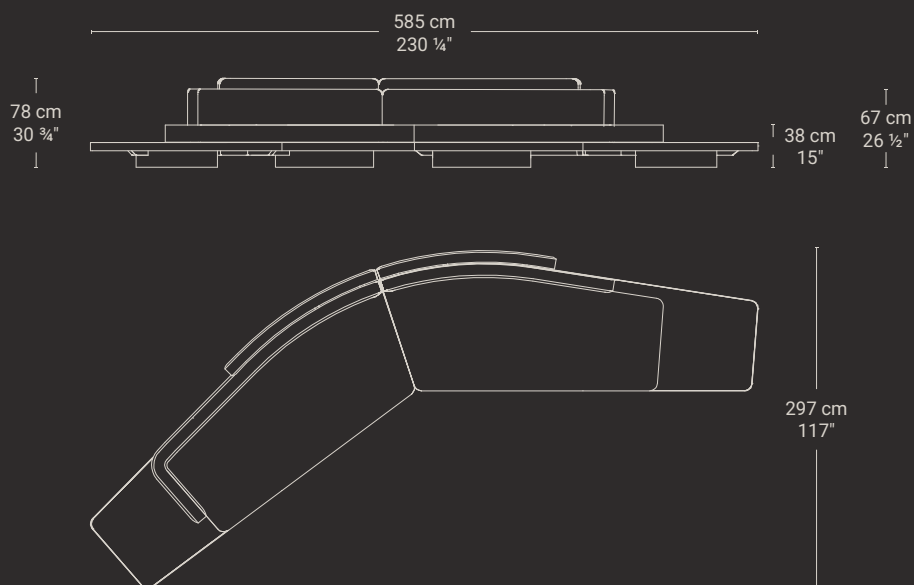

ORSS014 Ordos Sofa con braccioli di marmo destro 585x297x78
Ordos Sofa with marble armrest right 585x297x78

ORSS017 Ordos Sofa con bracciolo di marmo destro 585x297x78_da blocco
Ordos Sofa with marble armrest right 585x297x78_solid

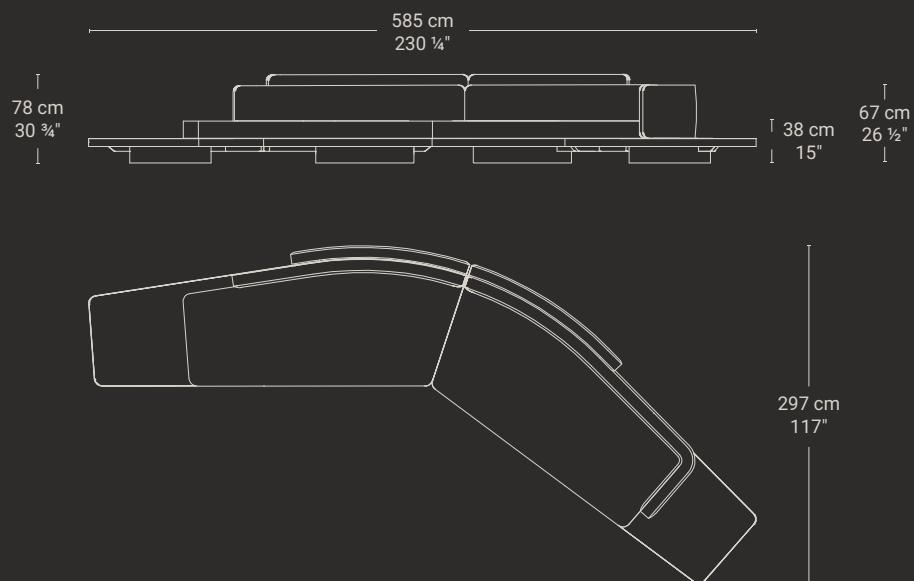

Ordos

ORSS004 Ordos Composizione 4 / Ordos Composition 4

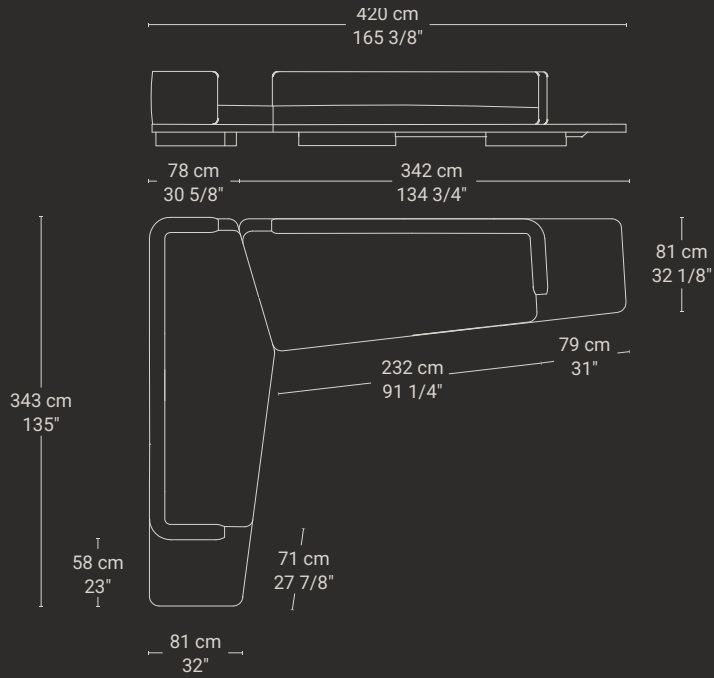

ORSS005 Ordos Composizione 5 / Ordos Composition 5

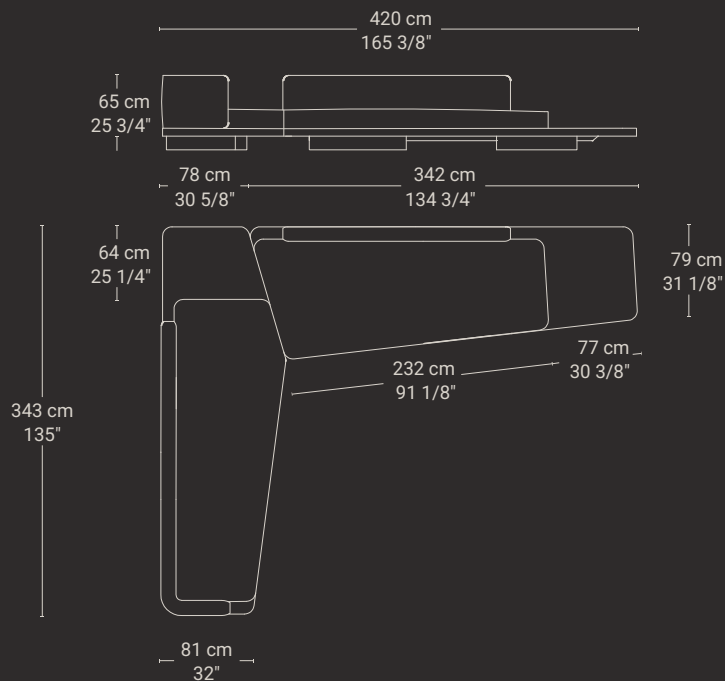

Ordos

ORSS006 Ordos Composizione 6 / Ordos Composition 6

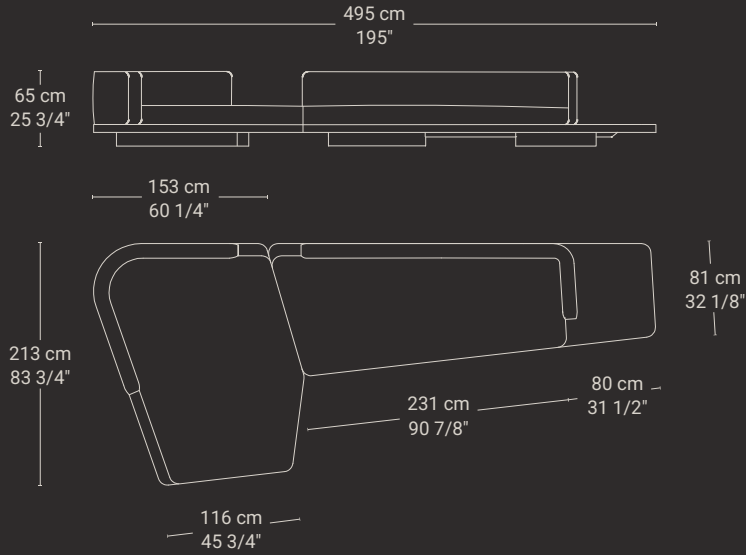

ORSS007 Ordos Composizione 7 / Ordos Composition 7

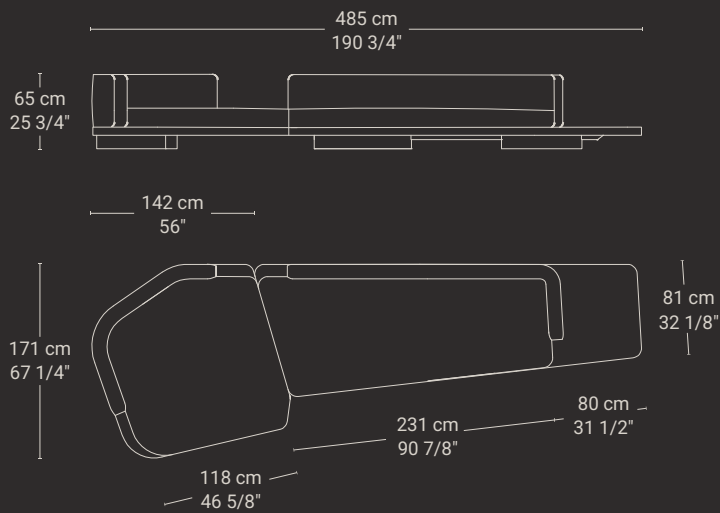

Ordos

- ORSS002 Ordos Dormeuse sinistra con marmo 361x165x67
Ordos Dormeuse left with marble 361x165x67
- ORSS003 Ordos Dormeuse destra con marmo 361x165x67
Ordos Dormeuse right with marble 361x165x67
- ORSS027 Ordos Dormeuse destra con marmo 361x165x67_da blocco
Ordos Dormeuse right with marble 361x165x67_solid
- ORSS028 Ordos Dormeuse sinistra con marmo 361x165x67_da blocco
Ordos Dormeuse left with marble 361x165x67_solid

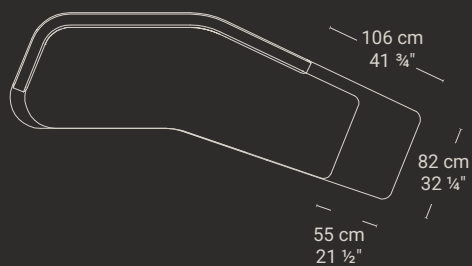
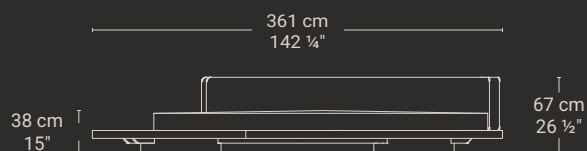
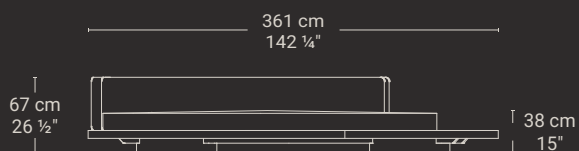

ORSS002
ORSS028

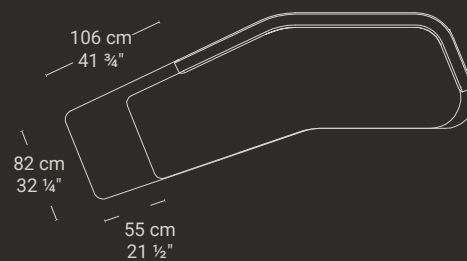

ORSS003
ORSS027

Ordos

- ORSS023 Ordos Dormeuse destra con bracciolo in marmo
Ordos Dormeuse right with marble armrest
- ORSS024 Ordos Dormeuse sinistra con bracciolo in marmo
Ordos Dormeuse left with marble armrest
- ORSS025 Ordos Dormeuse destra con bracciolo in marmo _da blocco
Ordos Dormeuse right with marble armrest_solid
- ORSS026 Ordos Dormeuse sinistra con bracciolo in marmo _da blocco
Ordos Dormeuse left with marble armrest_solid

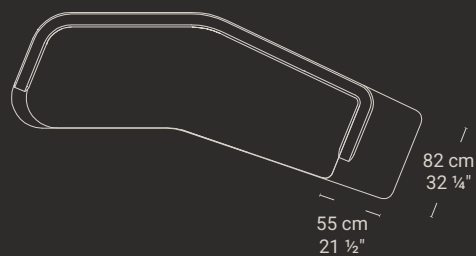
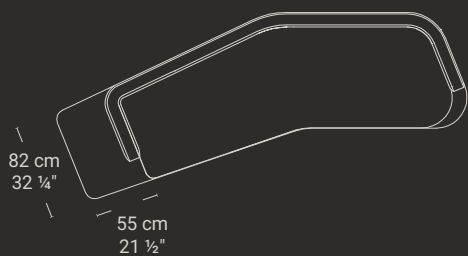

ORSS023
ORSS025

ORSS024
ORSS026

Sao Miguel

design by Stefano Gallizioli





Sao Miguel



SAO MIGUEL Dormeuse right, SAO MIGUEL Pouf 220x88x38
Tessuto Samoiedo Bordeaux / Samoiedo Fabric Bordeaux





SAO MIGUEL Sofa 380x160x83, SAO MIGUEL Pouf 130x81x38
Tessuto Tatanka nero / Tatanka Fabric Black





SAO MIGUEL Dormeuse sinistra con marmo /
Dormeuse left with marble
Marmo Verde Borgogna, Tessuto Vancouver verde /
Verde Borgogna marble, Vancouver Fabric Green

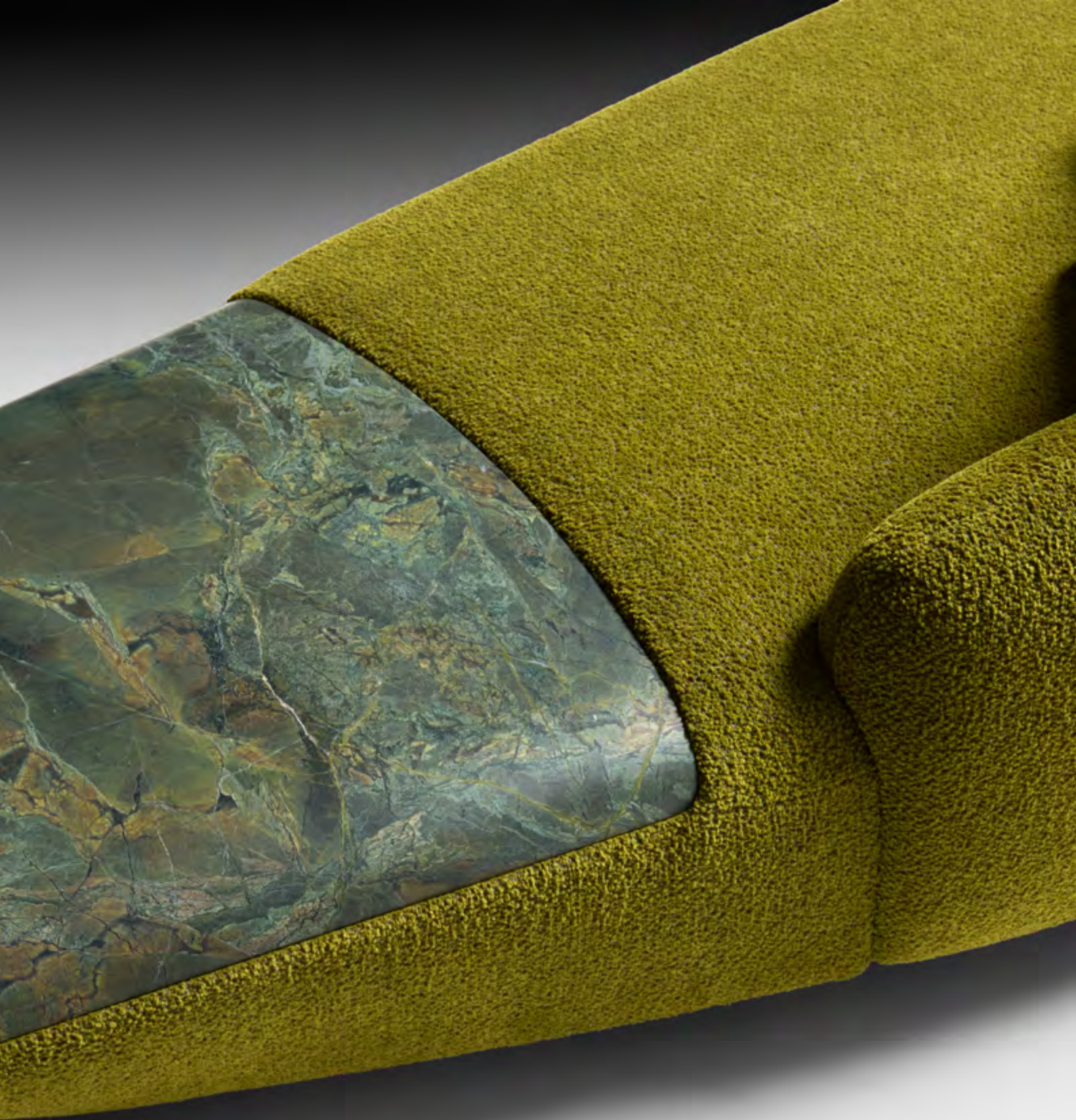

Sao Miguel

Divano e pouf, design by Stefano Gallizioli

Un angolo remoto e protetto, dove l'oceano abbraccia i promontori e ogni corrente è placata. È da questa visione naturale che nasce la collezione Sao Miguel, ispirata all'isolotto omonimo delle Azzorre, una terra selvaggia e affascinante. I suoi profili, curvilinei e collinari, sono idealmente ricreati nel design della collezione disegnata da Stefano Gallizioli. Il divano supera la concezione tradizionale di imbottito diventando un'isola attorno alla quale ruota la convivialità, un rifugio di comfort e riposo: distintivo è il piano d'appoggio realizzato con una lastra in marmo che sorregge i generosi e morbidi volumi rivestiti in tessuto. Abbinato, il suo grande pouf che ne asseconda le linee in modo complementare. La collezione (disponibile con un abaco di elementi per composizioni modulari) si arricchisce poi di tavolini e pouf, che conservano la stessa forza evocativa del divano unita a un'estrema versatilità.

Modular sofa & pouf designed by Stefano Gallizioli

A remote and secluded corner where ocean embraces headlands, and every current is tamed. The Sao Miguel collection is born from this vision and inspired by its small namesake island in the Azores, a fascinatingly wild land with curved lines and hilly contours that are perfectly mirrored in the Gallizioli collection. Challenging the traditional concept of furniture design, the sofa becomes an island, a shelter and welcoming safe space to find comfort and rest. Its distinctive marble top is created with a slab supporting the generous and soft volumes covered in fabric while a large complementary pouf echoes its lines. The collection, available with endless elements for modular compositions, is further enriched with coffee tables and ottomans that retain the same evocative power and versatility of the sofa.

Sao Miguel

specifiche prodotto/
product specifications

SAOP001

Sao Miguel Pouf 89x87x38

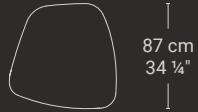
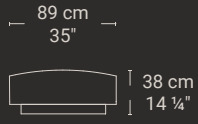

SAOP004

Sao Miguel Pouf 108x88x38



SAOP002

Sao Miguel Pouf 130x81x38

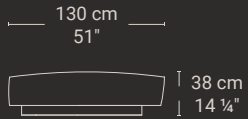

SAOP005

Sao Miguel Pouf 152x90x38



Sao Miguel

SAOP003 Sao Miguel Pouf 221x88x38

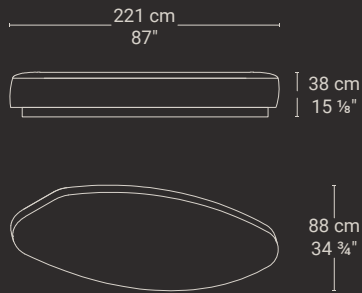

SAOP006 Sao Miguel Pouf destro con marmo 220x88x38
Sao Miguel Pouf right with marble 220x88x38

SAOP007 Sao Miguel Pouf sinistro con marmo 220x88x38
Sao Miguel Pouf left with marble 220x88x38

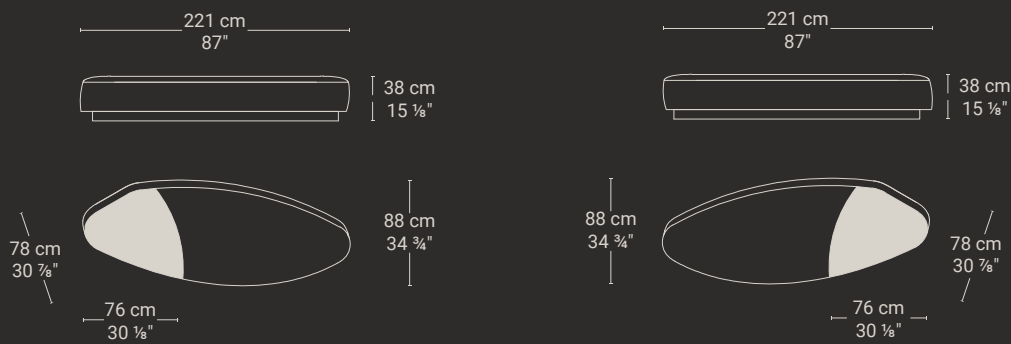

SAOP006

SAOP007

Sao Miguel

SAOP008 Sao Miguel Pouf Doppio 221x88x38 destro
Sao Miguel Pouf Double 221x88x38 right

SAOP009 Sao Miguel Pouf Doppio 221x88x38 sinistro
Sao Miguel Pouf Double 221x88x38 left



SAOP008



SAOP009

SAOP010 Sao Miguel Pouf Doppio con marmo piccolo 221x88x38 destro
Sao Miguel Pouf Double with marble small 221x88x38 right

SAOP011 Sao Miguel Pouf Doppio con marmo piccolo 221x88x38 sinistro
Sao Miguel Pouf Double with marble small 221x88x38 left

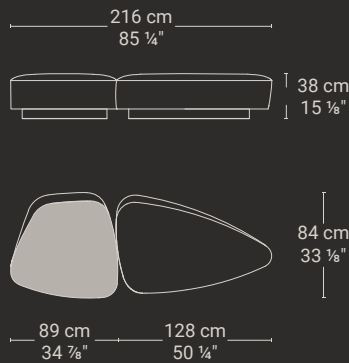

SAOP010

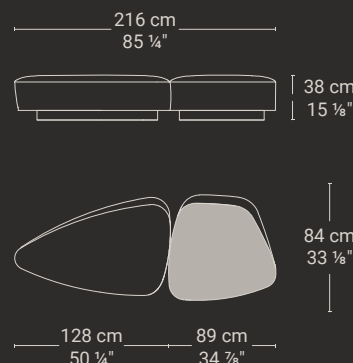

SAOP011

Sao Miguel

SAOP012 Sao Miguel Pouf Doppio con marmo grande 221x88x38 destro
Sao Miguel Pouf Double with marble big 221x88x38 right

SAOP013 Sao Miguel Pouf Doppio con marmo grande 221x88x38 sinistro
Sao Miguel Pouf Double with marble big 221x88x38 left

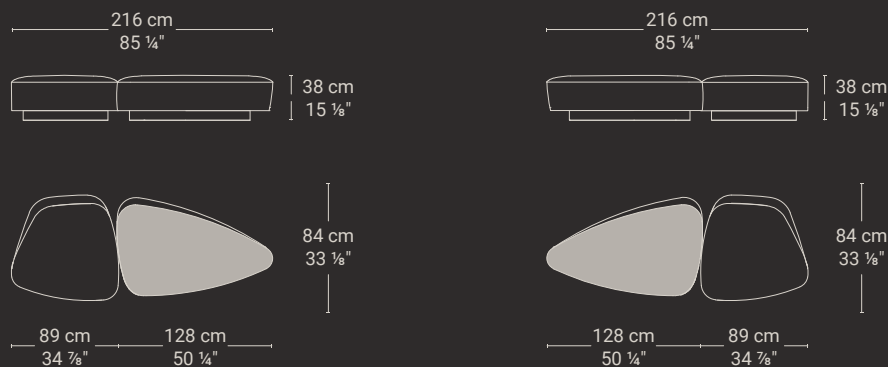

SAOP012

SAOP013

SAOP014 Sao Miguel Pouff Piccolo 99x80x38
Sao Miguel Pouff Small 99x80x38

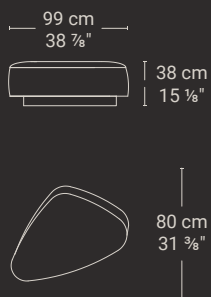

Sao Miguel

SAQP015

Sao Miguel Pouff 256x88x38

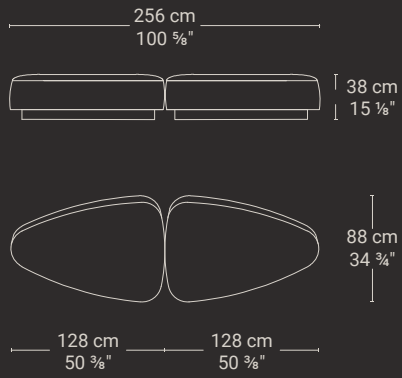

SAQP016

Sao Miguel Pouff con marmo 256x88x38
Sao Miguel Pouff with marble 256x88x38

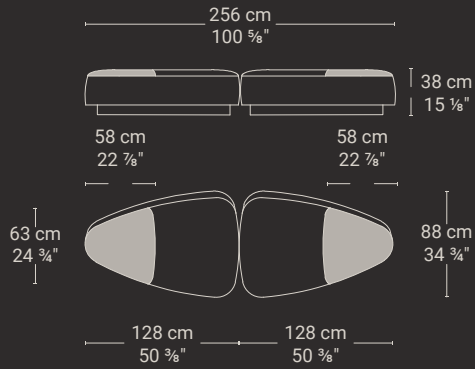

Sao Miguel

SAOS001

Sao Miguel Sofa 380x160x83

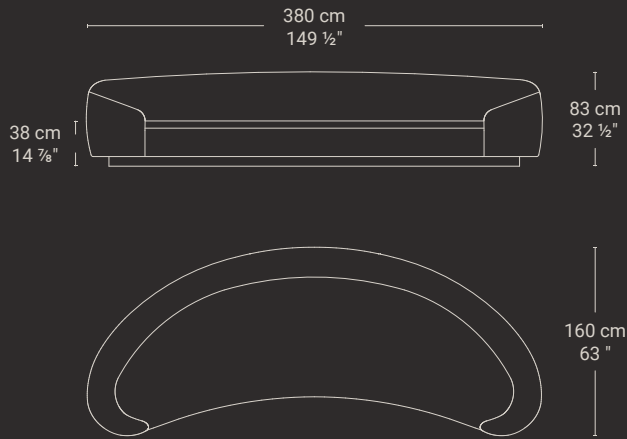

SAOS031

Sao Miguel Divano piccolo 280x130x76
Sao Miguel Sofa small 280x130x76

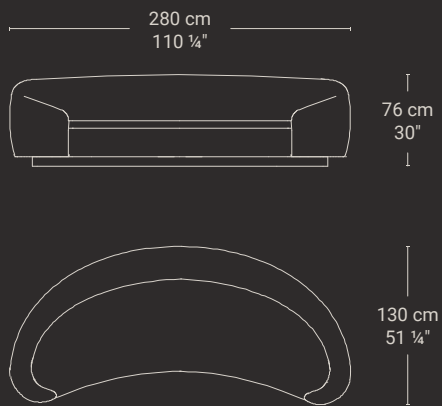

Sao Miguel

SAOS024 Sao Miguel Sofa aperto 380x160x72
Sao Miguel Sofa open 380x160x72

SAOS024_SM Sao Miguel Sofa aperto 380x160x72 smontato
Sao Miguel Sofa open 380x160x72 disassembled

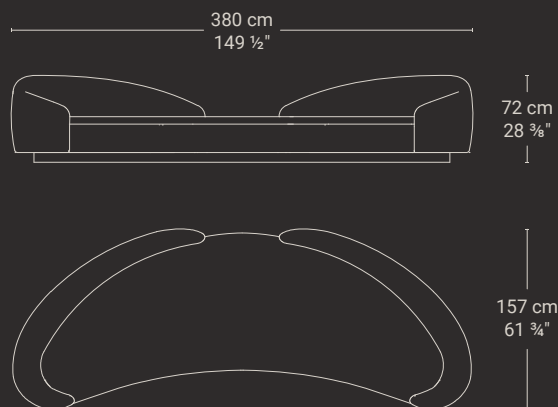

SAOS023 Sao Miguel Sofa con marmo 380x160x72
Sao Miguel Sofa with marble 380x160x72

SAOS023_SM Sao Miguel Sofa con marmo 380x160x72 smontato
Sao Miguel Sofa with marble 380x160x73 disassembled

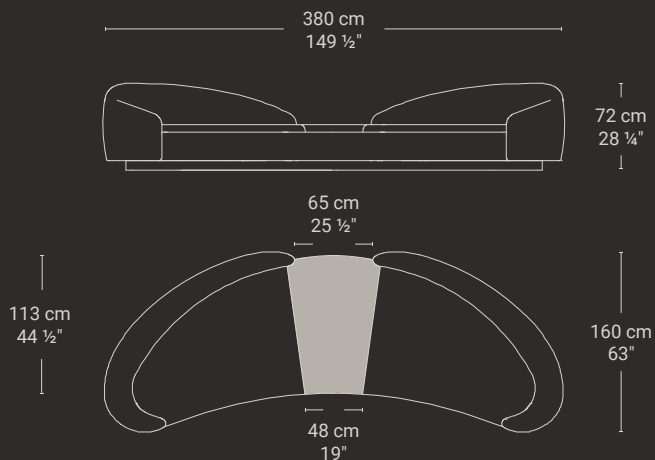

Sao Miguel

SAOS032

Sao Miguel Divano Ali 366x178x83
Sao Miguel Sofa Wings 366x178x83

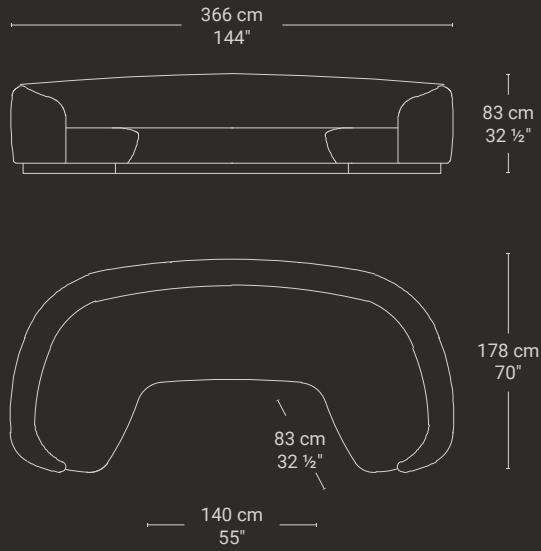

SAOS033

Sao Miguel Divano Ali con marmo 366x178x72
Sao Miguel Sofa Wings with marble 366x178x72

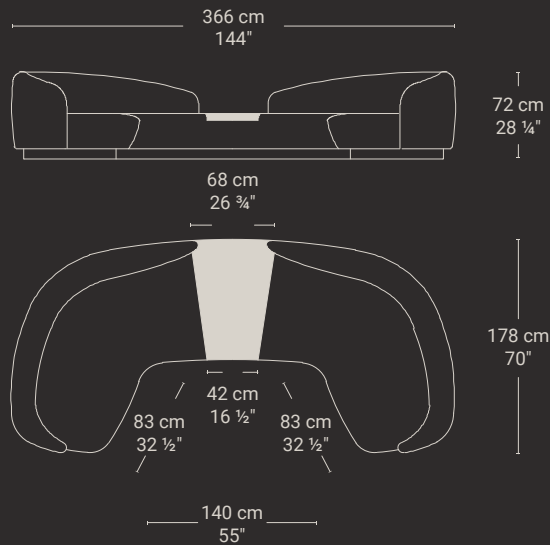

Sao Miguel

SAOS034 Sao Miguel Divano ali sinistro con marmo 365x178x83
Sao Miguel Sofa Wings left with marble 365x178x83

SAOS035 Sao Miguel Divano ali destro con marmo 365x178x83
Sao Miguel Sofa Wings right with marble 365x178x83

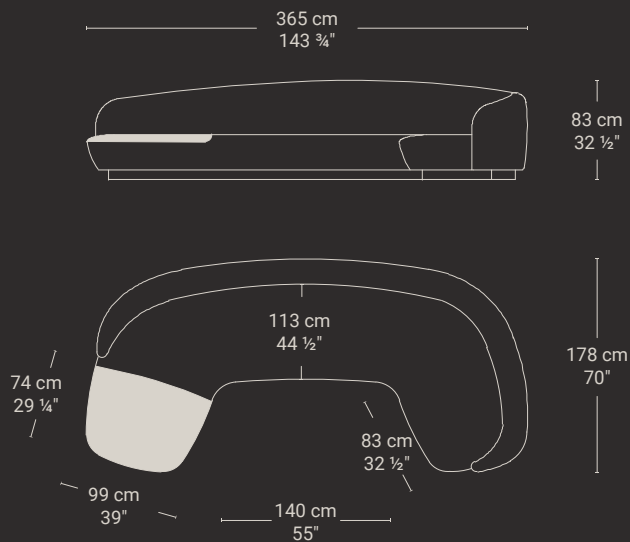

SAOS034

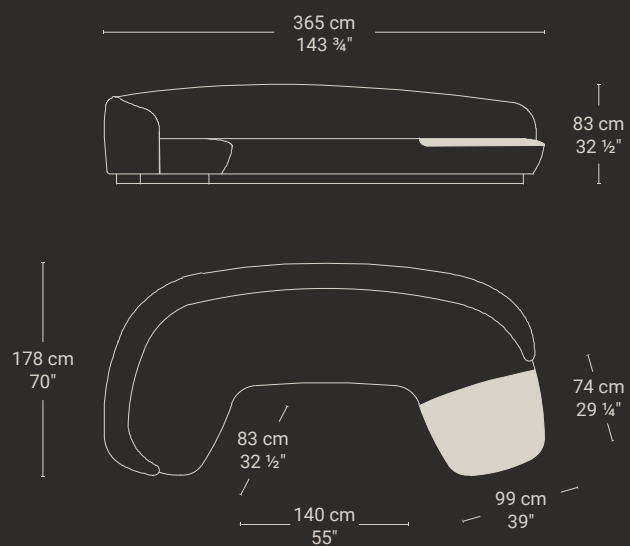

SAOS035

Sao Miguel

SAOS025 Sao Miguel divano sinistro 366x190x83
Sao Miguel Sofa left 366x190x83

SAOS028 Sao Miguel divano destro 366x190x83
Sao Miguel Sofa right 366x190x83

SAOS025_SM Sao Miguel divano sinistro 366x190x83 smontato
Sao Miguel Sofa left 366x190x83 disassembled

SAOS028_SM Sao Miguel divano destro 366x190x83 smontato
Sao Miguel Sofa right 366x190x83 disassembled

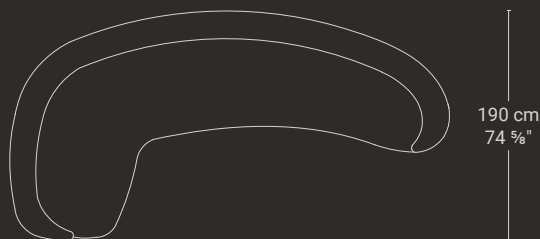
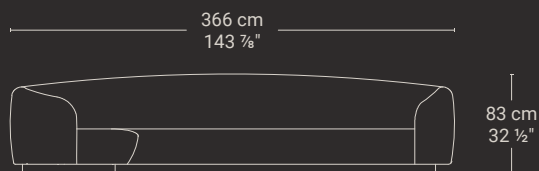

SAOS025
SAOS025_SM

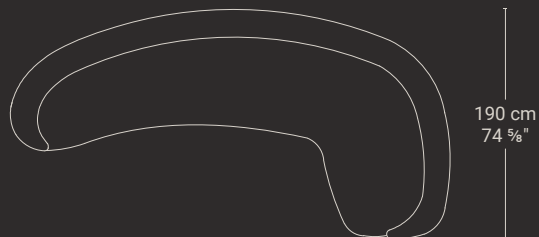
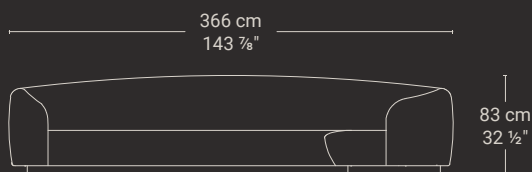

SAOS028
SAOS028_SM

Sao Miguel

SAOS026 Sao Miguel divano sinistro aperto 351x155x72
Sao Miguel Sofa left open 351x155x72

SAOS029 Sao Miguel divano destro aperto 351x155x72
Sao Miguel Sofa right open 351x155x72

SAOS026_SM Sao Miguel divano sinistro aperto 351x155x72 smontato
Sao Miguel Sofa left open 351x155x72 disassembled

SAOS029_SM Sao Miguel divano destro aperto 351x155x72 smontato
Sao Miguel Sofa right open 351x155x72 disassembled

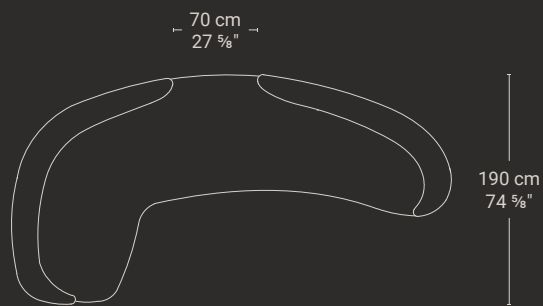
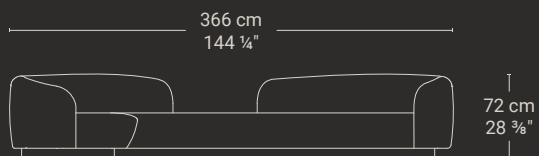

SAOS026
SAOS026_SM

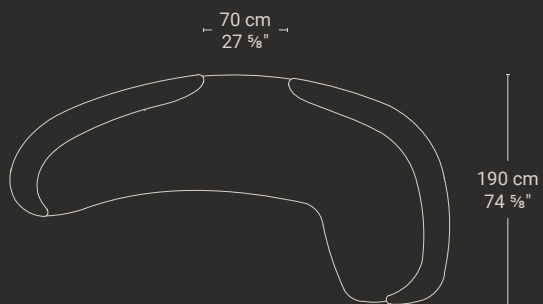
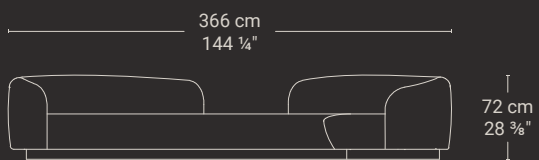

SAOS029
SAOS029_SM

Sao Miguel

- SAOS027 Sao Miguel divano sinistro aperto con marmo 366x189x72
Sao Miguel Sofa left open with marble 366x189x72
- SAOS030 Sao Miguel divano destro aperto con marmo 366x189x72
Sao Miguel Sofa right open with marble 366x189x72
- SAOS027_SM Sao Miguel divano sinistro aperto con marmo 366x189x72 smontato
Sao Miguel Sofa left open with marble 366x189x72 disassembled
- SAOS030_SM Sao Miguel divano destro aperto con marmo 366x189x72 smontato
Sao Miguel Sofa right open with marble 366x189x72 disassembled

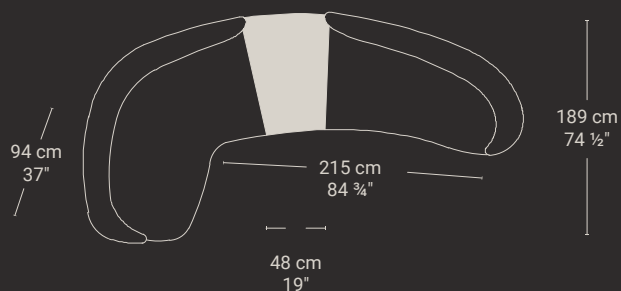

SAOS027
SAOS027_SM

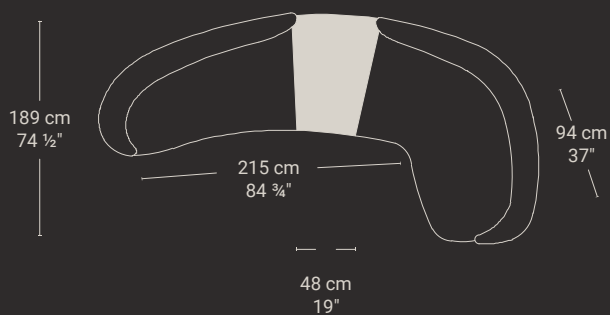
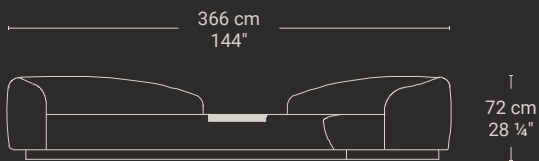

SAOS030
SAOS030_SM

Sao Miguel

specifiche prodotto/
product specifications

SAOS003 Sao Miguel Dormeuse destra 351x155x72
Sao Miguel Dormeuse right 351x155x72

SAOS007 Sao Miguel Dormeuse sinistra 351x155x72
Sao Miguel Dormeuse left 351x155x72

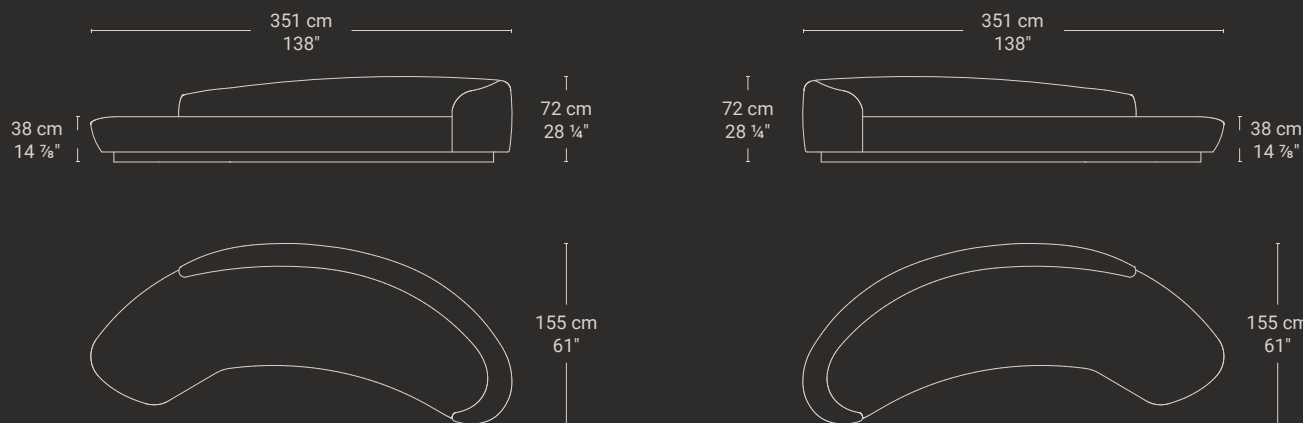

SAOS003

SAOS007

SAOS021 Sao Miguel Dormeuse destra con marmo 351x110x72
Sao Miguel Dormeuse right with marble 351x110x72

SAOS022 Sao Miguel Dormeuse sinistra con marmo 351x110x72
Sao Miguel Dormeuse left with marble 351x110x72

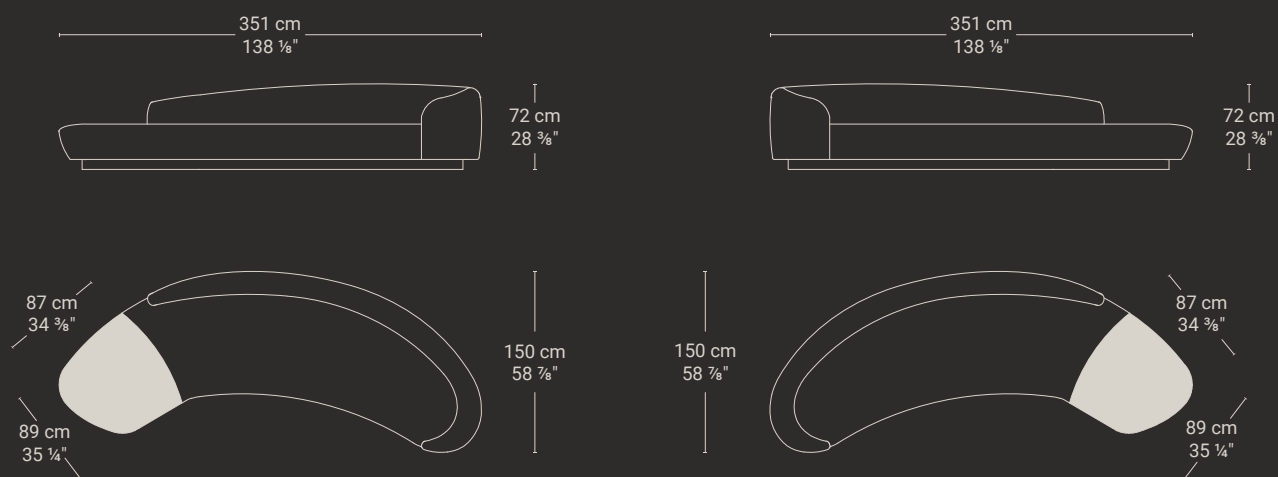

SAOS021

SAOS022

Sao Miguel

SAOS002 Sao Miguel Dormeuse sinistra con marmo 295x120x70
Sao Miguel Dormeuse left with marble 295x120x70

SAOS036 Sao Miguel Dormeuse destra con marmo 295x120x70
Sao Miguel Dormeuse right with marble 295x120x70

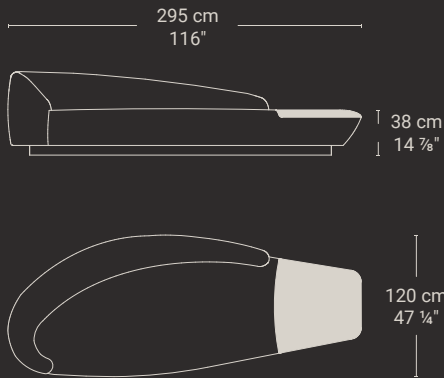

SAOS002

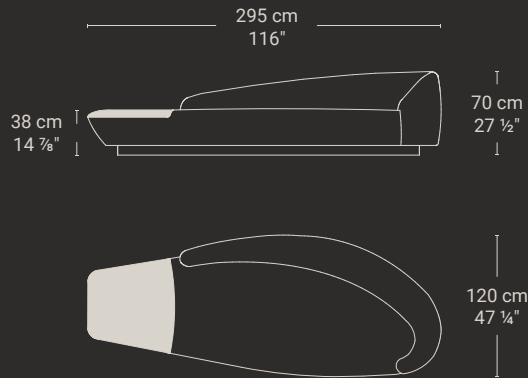

SAOS036

Terrae

design by Draw Studio





Terrae

divani / sofas



158

TERRAE Composizione 2 / Composition 2

Marmo Verde Antigua, Tessuto Tatanka avorio / Verde Antigua
marble, Tatanka Fabric Ivory



Terrae



Terrae

divani / sofas



161

TERRAE Composizione 4 / Composition 4
Marmo Cipollino misto, Pelle naturale Nabuk /
Cipollino Misto marble, Nabuk Natural Leather

Terrae

Sistema modulare di divani, design by Draw Studio

Gli elementi di seduta modulare della collezione TERRAE sono caratterizzati da un contrasto evidente tra un 'guscio' composto da piani netti e rigorosi in marmo e un imbottito abbondante e accogliente. Le lastre di marmo disposte alle estremità abbracciano e contengono i cuscini, esaltandone la ricercata morbidezza.

La forma inclinata del divano in pianta e gli schienali asimmetrici, rompono la tradizionale linearità dei volumi e creano un paesaggio dinamico e multiforme.

Diverse sono le composizioni possibili e altrettanto numerosi sono i dettagli ricercati, come la lavorazione a cuspide che incornicia i fianchi in pietra, ripresa anche lungo lo zoccolino frontale, o come le cuciture sartoriali che definiscono con precisione la forma dell'imbottito.

Una selezione di pellami e tessuti d'eccellenza abbinata a pietre originali e ricercate completano la collezione.

Qualità e comfort sono all'origine della scelta di una struttura a molle insacchettate della seduta rivestite da strati di gommapiuma a diverse densità e di un telaio in alluminio con fissaggi progettati ad hoc e perni torniti ricavati dal pieno.

L'abaco prevede lo sviluppo di moduli terminali, centrali e chaise longue con due modularità (1000 cm e 1850 cm) per articolare composizioni lineari, angolari o più dinamiche con forme non convenzionali che abbracciano il living.

Modular sofa system designed by Draw Studio

The TERRAE collection's modular seating showcases a dramatic contrast between a "shell" made of rigorous, defined marble tops and plush, inviting upholstery. The marble ends cradle the cushions, accentuating their luxurious softness.

The design's inclined profile and asymmetrical backrests disrupt conventional shapes, crafting a dynamic and varied visual landscape.

The collection is rich in intricate details, from the cusp carving framing the stone sides which is echoed along the front plinth, to the precise stitching outlining the upholstery. A curated selection of premium leather, fabrics, and distinctive stones enhances the collection's allure.

The seating's quality and comfort stem from a spring system encased in multi-density foam and an metal frame with custom fittings and metal pivots crafted from solid material.

The collection includes end and middle modules, and chaise longue in two sizes (1000 cm and 1850 cm), enabling linear, angular or more dynamic configurations, embracing the living space with their unique forms.

La collezione Terrae è disponibile su richiesta in diversi marmi e materiali (tessuti e pelli), previa verifica tecnica.

The Terrae collection is available on request in different marbles and materials (fabrics and leathers), after technical testing.

Terrae

TERT001 Terrae Terminale Destro 195x100x70
Terrae Terminal element right 195x100x70

TERT002 Terrae Terminale Sinistro 195x100x70
Terrae Terminal element left 195x100x70

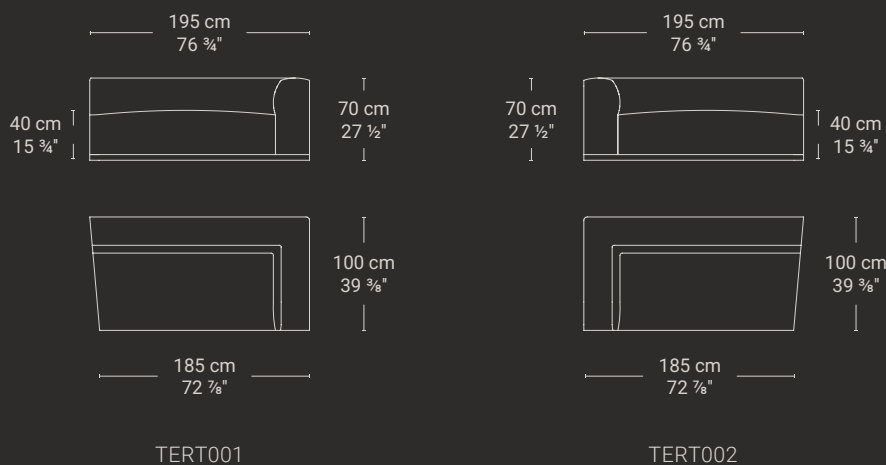

TERT003 Terrae Terminale Destro 185x100x70
Terrae Terminal element right 185x100x70

TERT004 Terrae Terminale Sinistro 185x100x70
Terrae Terminal element left 185x100x70

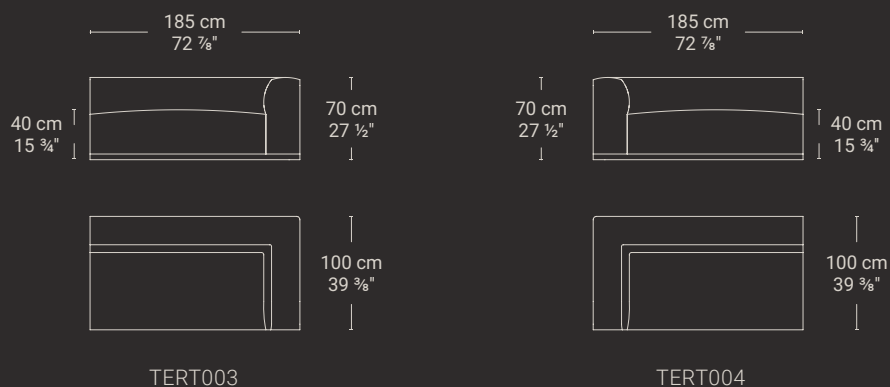

Terrae

TERP005 Terrae Panca Destra 195x100x70
Terrae Bench right 195x100x70

TERP006 Terrae Panca Sinistra 195x100x70
Terrae Bench left 195x100x70

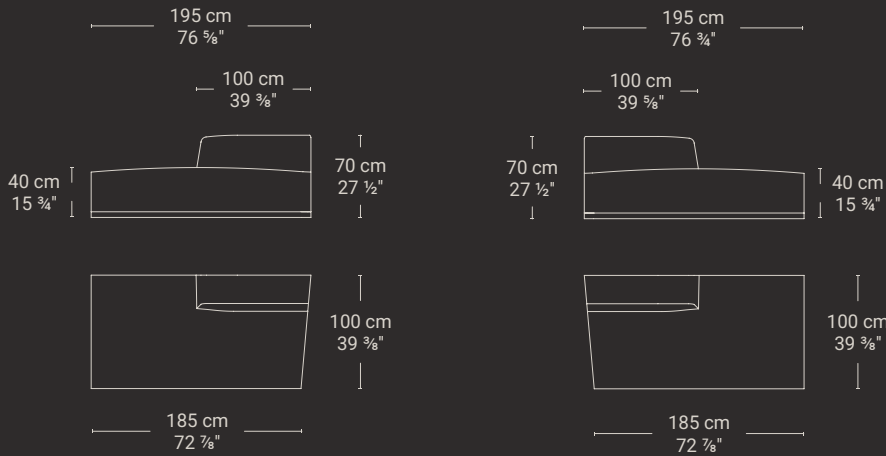

TERP005

TERP006

TERP007 Terrae Panca Destra 185x100x70
Terrae Bench right 185x100x70

TERP008 Terrae Panca Sinistra 185x100x70
Terrae Bench left 185x100x70

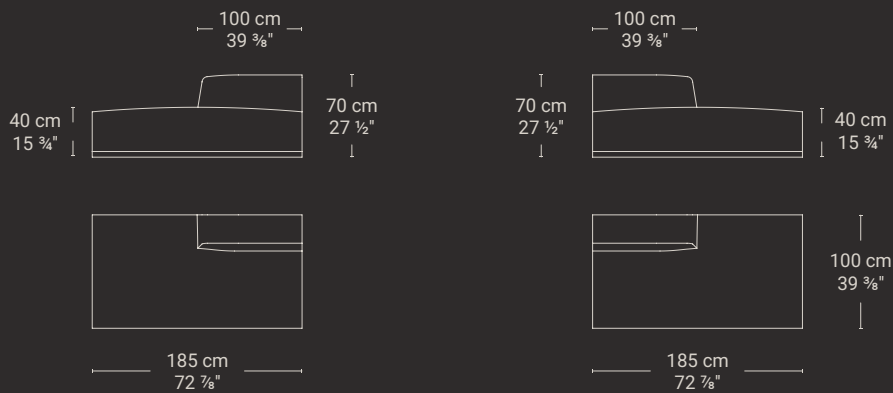

TERP007

TERP008

Terrae

TERE009 Terrae Elemento Centrale 200x100x70
Terrae Central element 200x100x70

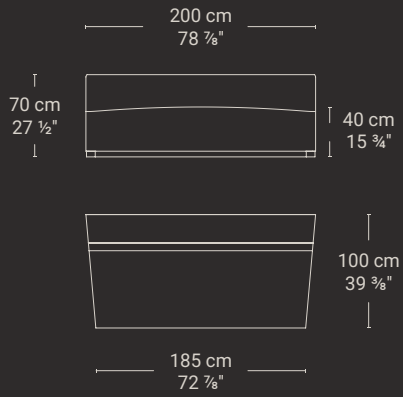

Terrae

TERC010 Terrae Composizione 1 / Terrae Composition 1

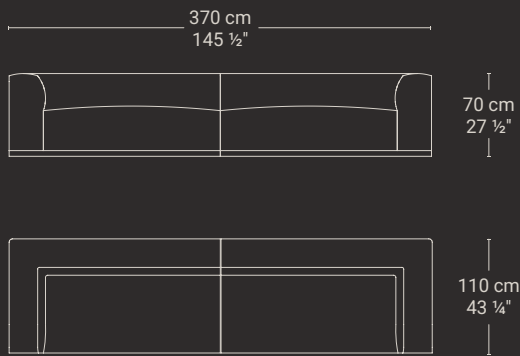

TERC011 Terrae Composizione 2 / Terrae Composition 2
TERC017 Terrae Composizione 8 / Terrae Composition 8

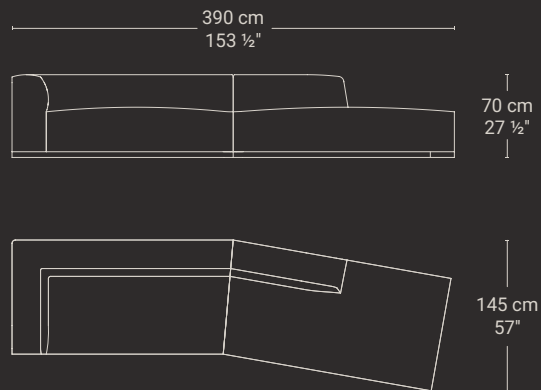

TERC011

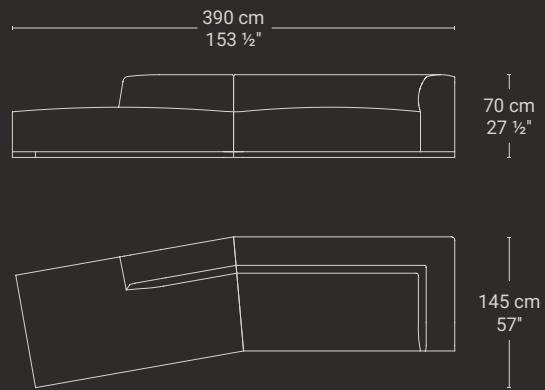

TERC017

Terrae

specifiche prodotto/
product specifications

TERC015 Terrae Composizione 6 / Terrae Composition 6
TERC016 Terrae Composizione 7 / Terrae Composition 7



TERC015

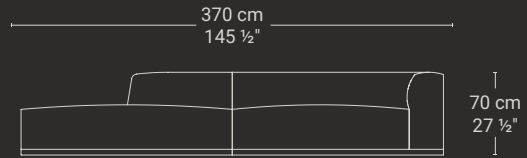

TERC016

TERC018 Terrae Composizione 9 / Terrae Composition 9

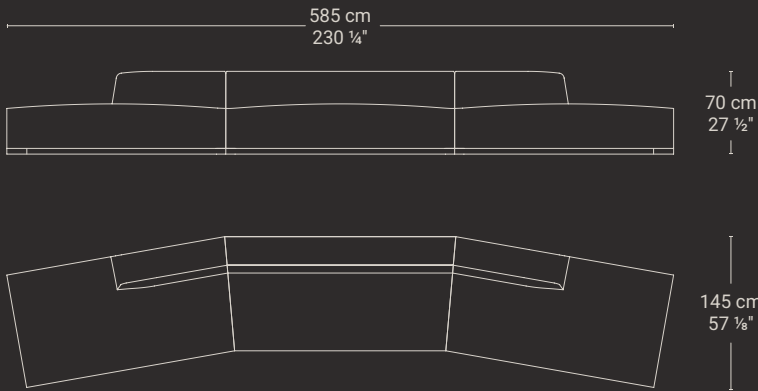

Terrae

TERC012 Terrae Composizione 3 / Terrae Composition 3

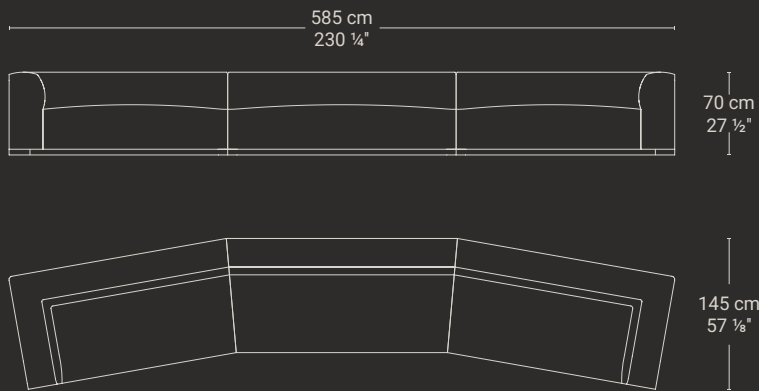

TERC013 Terrae Composizione 4 / Terrae Composition 4

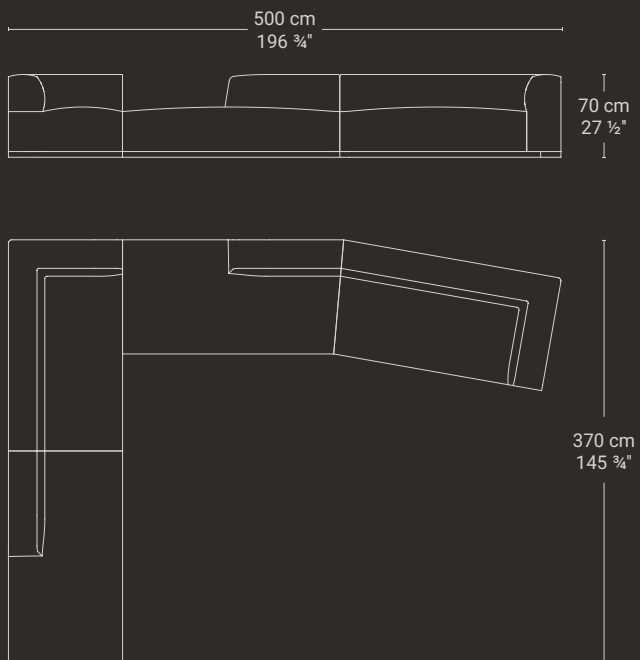

Terrae

TERC014 Terrae Composizione 5 / Terrae Composition 5

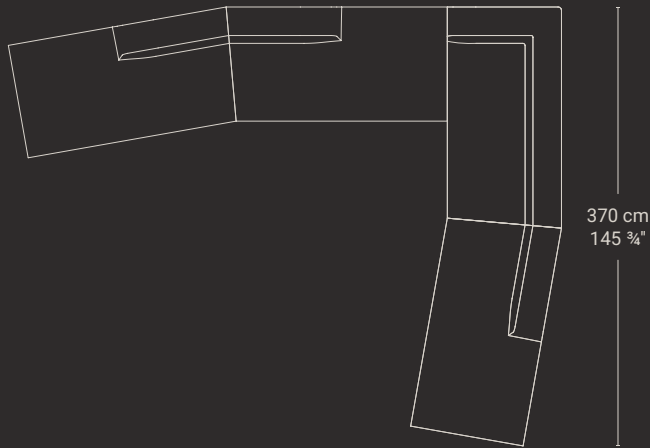
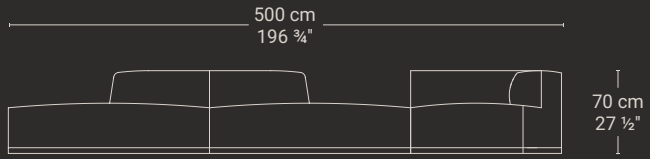

specifiche prodotto/
product specifications

Theia

design by STUDIOPIVA



Theia

Sgabelli, design by STUDIOPIVA

La forma circolare del piano è l'elemento condiviso da tutti i modelli della serie Theia: tavoli, tavolini e sgabelli, che evocano nel nome l'omonimo pianeta che 4 miliardi di anni fa andò in collisione con la Terra (il cosiddetto "impatto gigante"), producendo la formazione del nostro unico satellite, la Luna. Questo evento galattico ed originario è rievocato dalle forme essenziali, quasi lunari, dei piani degli arredi Theia.

Tutti gli elementi della collezione, utilizzabili anche in contesti outdoor, sono caratterizzati da una struttura in fusione di bronzo costituita da un piano ad anello da cui si allungano le tre gambe (quattro nella versione tavolo da pranzo con diam. 180 cm); alla struttura, sagomata ad arte, aderiscono, quasi in simbiosi, gli inserti in marmo delle gambe e il piano - in marmo nel caso di tavoli e tavolini, rivestito in pelle Nabuk per gli sgabelli, disponibile in altre varianti di pelle o tessuto.

Stools designed by STUDIOPIVA

The top circular shape is the element shared by all Theia range models. Tables, coffee tables and stools, with a name which evokes the planet that collided with the Earth four billion years ago (the "giant impact"), creating the Moon. This galactic and original event is suggested by the essential, almost lunar shapes of the tops of Theia furnishings.

The collection elements, which can be used outdoors, feature a cast bronze structure consisting of a ring-shaped top from which three legs (four in the dining table version with a 180 cm diameter) extend. The legs' marble inserts symbiotically adhere to the artfully shaped structure. The tables and coffee tables' top are in marble, the stools covered in Nabuck leather, and are available in other leather or fabric versions.

Theia

<u>THES009</u>	Theia Sgabello D48X502 Bronzo Theia Stool D48X50 Bronze
<u>THES010</u>	Theia Sgabello D48X50 Alluminio Theia Stool D48X50 Aluminium

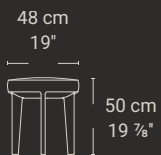

Onis

design by Draw Studio



ONIS Mobile contenitore / Storage Unit 280x55x60
Marmo Tobacco Brown, metallo marrone lucido
Tobacco Brown marble, Brown Glossy Metal





ONIS Comodino dx / Night table right
Marmo Oyster White, metallo nuvolato opaco Gold /
Oyster White marble, Matt Cloudy Gold Metal

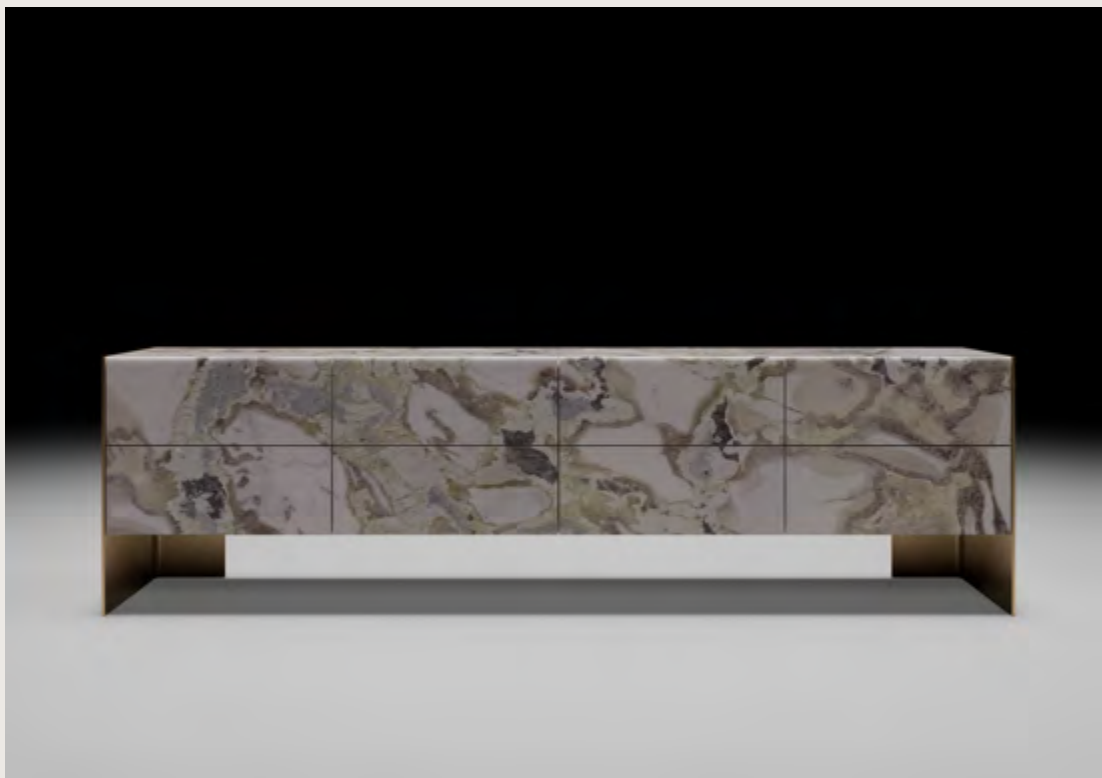

ONIS Mobile contenitore / Storage Unit 282x55x80
Marmo Oyster White, metallo nuvolato opaco Gold /
Oyster White marble, Matt Cloudy Gold Metal

Onis

Mobile contenitore, design by Draw Studio

Evoca l'architettura sospesa dei ponti, dove l'equilibrio e la forza si intrecciano in una perfetta simbiosi. Con una struttura completamente a sbalzo, Onis è composto da moduli di contenimento in marmo, ripetuti a creare una sequenza lineare pura, sostenuto alle estremità da una base in metallo che abbraccia i fianchi. Pochi gli elementi in gioco, dunque, che enfatizzano il rigore costruttivo. Spazio allora ai dettagli: finiture materiche, ossidazioni, acidature o bruniture, per le basi che contrastano con la patinata raffinatezza della pietra; una gola a "L" che percorre il frontale e facilita l'apertura; gli interni rifiniti con laccature e pelle. La collezione, che abbraccia tre versioni di mobili e il comodino, si allinea con versatile raffinatezza e personalizzazione a ogni stile, dagli ambienti più classici al gusto più eclettico e moderno, assecondando ogni funzione: la praticità di un ufficio o la decorazione di un ricercato living.

Storage cabinet designed by Draw Studio

Onis recalls the architecture suspension of bridges, where balance and strength intertwine in perfect harmony. Its cantilevered structure, with marble modules replicated to create a pure linear sequence, is supported by a metal base embracing its sides. With the less is more vision, few elements are involved, thus emphasizing the constructive rigor and attention to detail and material finishes: cloudy metal for the bases that contrast with the polished refinement of the stone; an L-shaped groove down the front; the interiors finished with lacquer and leather. Available in three sizes with also a bedside table, the collection can be customized and is fully aligned in its refined versatility, supporting every function: from the most traditional environments to the most eclectic and modern taste, to the practicality of an office or the decoration of a refined living room.

Onis

ONIC001 Onis Mobile contenitore 282x55x80 Nuvolato Opaco Gold / Silver
Onis Storage Unit 282x55x80 Matt Cloudy Gold / Silver

ONIC006 Onis Mobile contenitore 282x55x80 Lucido
Onis Storage Unit 282x55x80 Glossy

ONIC011 Onis Mobile contenitore 282x55x80 Spazzolato
Onis Storage Unit 282x55x80 Brushed

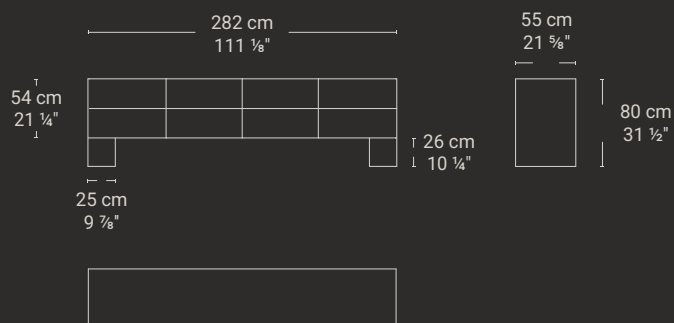

ONIC002 Onis Mobile contenitore 280x55x60 Nuvolato Opaco Gold / Silver
Onis Storage Unit 280x55x60 Matt Cloudy Gold / Silver

ONIC007 Onis Mobile contenitore 280x55x60 Lucido
Onis Storage Unit 280x55x60 Glossy

ONIC012 Onis Mobile contenitore 280x55x60 Spazzolato
Onis Storage Unit 280x55x60 Brushed

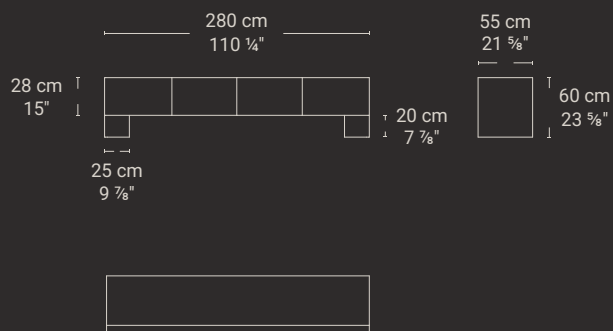

Onis

- ONIC003 Onis Mobile contenitore 267x55x60 Nuvolato Opaco Gold / Silver
Onis Storage Unit 267x55x60 Matt Cloudy Gold / Silver
- ONIC008 Onis Mobile contenitore 267x55x60 Lucido
Onis Storage Unit 267x55x60 Glossy
- ONIC013 Onis Mobile contenitore 267x55x60 Spazzolato
Onis Storage Unit 267x55x60 Brushed

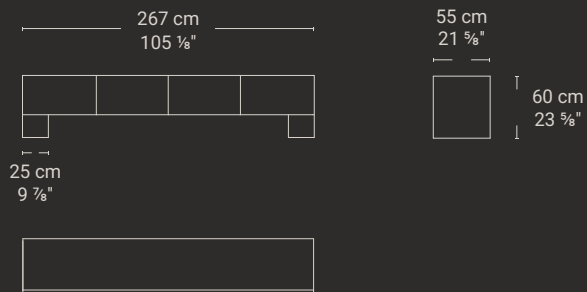

- ONIC004 Onis Comodino dx 65x45x43 Nuvolato Opaco Gold / Silver
Onis Night table right 65x45x43 Matt Cloudy Gold / Silver
- ONIC009 Onis Comodino dx 65x45x43 Lucido
Onis Night table right 65x45x43 Glossy
- ONIC014 Onis Comodino dx 65x45x43 Spazzolato
Onis Night table right 65x45x43 Brushed

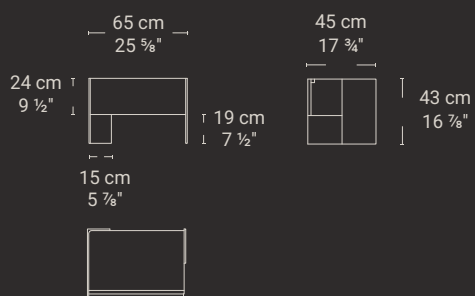

Onis

- ONIC005 Onis Comodino sx 65x45x43 Nuvolato Opaco Gold / Silver
Onis Night table left 65x45x43 Matt Cloudy Gold / Silver
- ONIC010 Onis Comodino sx 65x45x43 Lucido
Onis Night table left 65x45x43 Glossy
- ONIC015 Onis Comodino sx 65x45x43 Spazzolato
Onis Night table left 65x45x43 Brushed

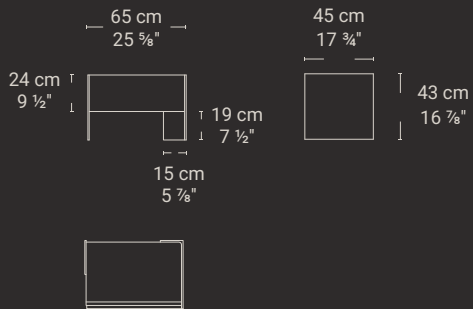

Adym

design by Gabriele e Oscar Buratti



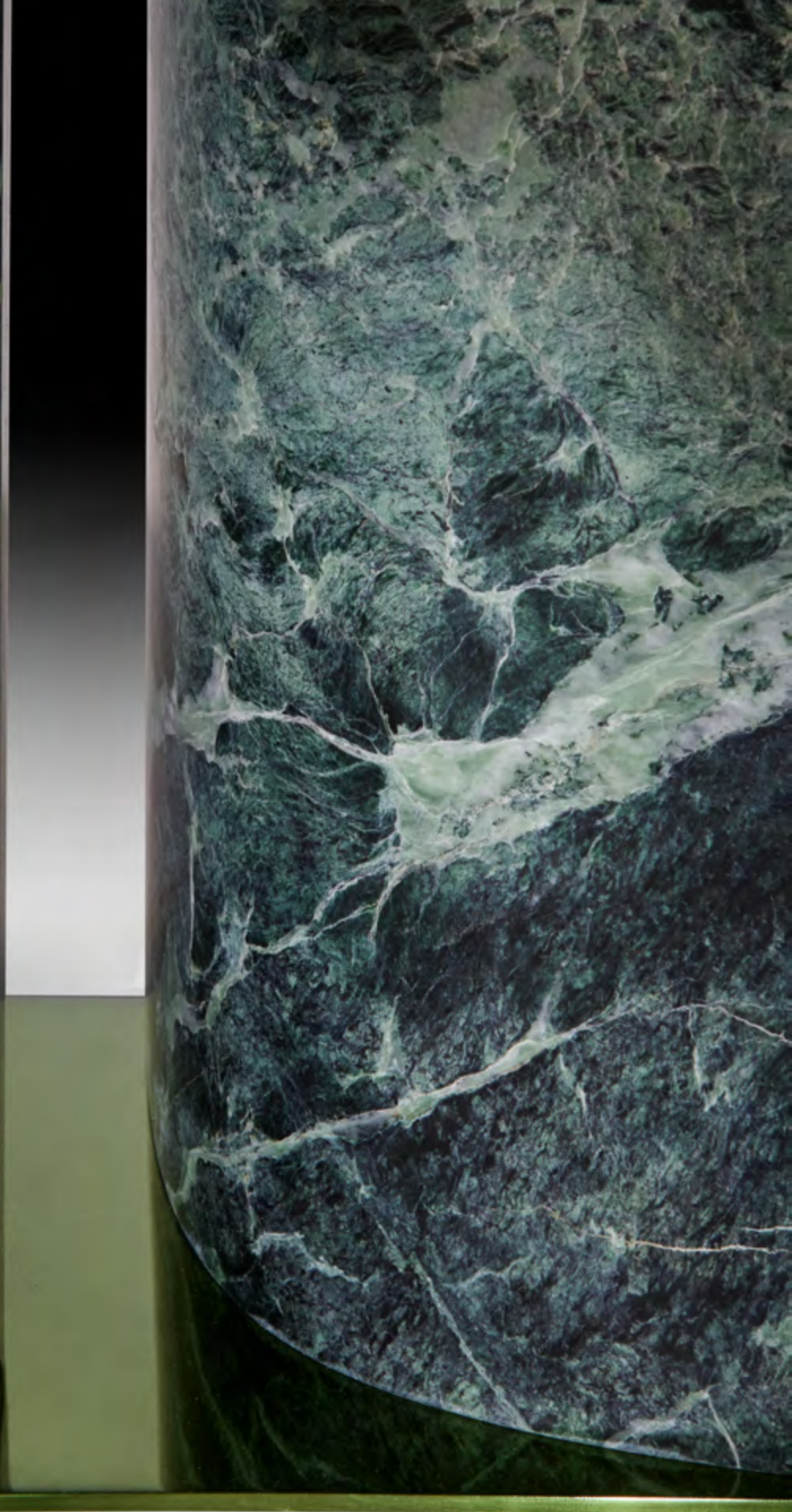



ADYM Tavolo / Table
Marmo Verde Alpi / Verde Alpi marble



Adym

Tavolo, design by Gabriele e Oscar Buratti

Il progetto del tavolo ADYM nasce dalla volontà dei due designer di modellare la pietra naturale, attraverso un'operazione scultorea che vuole valorizzare la poetica narrativa di un materiale antico e allo stesso tempo così moderno.

Il progetto è caratterizzato da una gamba sdoppiata, con lato piatto all'esterno e tondato verso l'interno, la cui forma varia continuamente a seconda del punto di vista.

I due elementi, che tendono l'uno verso l'altro senza mai toccarsi, grazie ad una fessura netta e passante al centro, sono i cardini di una composizione complessa e ricercata che esalta il materiale lapideo primario.

Innesti metallici e dettagli ricercati ne completano il disegno.

Protagonista del convivio, ADYM è un tavolo scultoreo, che indaga la tipologia classica del tavolo a due basi centrali che consentono di supportare piani con dimensioni importanti (320x120 cm).

Table designed by Gabriele and Oscar Buratti

Designed by Gabriele and Oscar Buratti, the ADYM table stems from a desire to sculpt natural stone into a narrative that celebrates its ancient roots and contemporary relevance.

The design features a distinctive split leg, presenting a flat exterior and a curved interior, offering a changing silhouette from different angles.

The legs converge but never touch, and use a central gap to form the foundation of a sophisticated structure that elevates the stone's natural beauty.

Metal inlays and meticulous details complete the design.

As a centerpiece, the ADYM table, reinterprets the traditional table using dual central supports accommodating a substantial top (320x120 cm).

Adym

ADYT001 Adym Tavolo 300x110x74
Adym Table 300x110x74

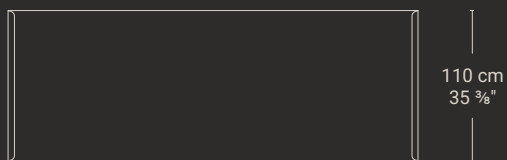
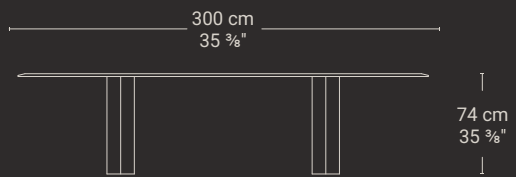

specifiche prodotto/
product specifications

Aves

design by Draw Studio





AVES Tavolo ovale / Oval table
Marmo Bronze Fantasy, metallo marrone lucido /
Bronze Fantasy marble, Brown Glossy Metal



Aves

Tavolo, design by Draw Studio

Il tavolo Aves è un'opera scultorea che annulla i volumi. Sono infatti le superfici a comporlo, come fosse un origami: i bordi sottili e allungati della base, la tensione orizzontale del piano. La forma cede alla materia in marmo il ruolo da protagonista. Aves si libra nello spazio con una leggerezza eterea, dispiegando le sue ali simmetriche separate al centro da un sottile foglio in metallo che riflette l'immagine della base in un gioco di continuità. Questo espediente scenografico amplia l'effetto prezioso delle lastre marmoree, arricchite da scanalature più profonde al centro e via via più rarefatte alle estremità. Un dettaglio che rivela l'autenticità del marmo ricavato dal pieno, e lo fa vibrare quando è colpito dalla luce.

Table designed by Draw Studio

The Aves table is a sculptural work of art that defies matter with its origami-like surfaces that compose it: the thin, elongated edges of the base and the horizontal tension of the top. Form is taken over by material with the marble taking the leading role. With ethereal-like lightness, Aves hovers in space, unfolding its symmetrical wings separated at the center by a thin metal sheet that mirrors the base in a play of continuous reflections. A scenography that enhances the precious effect of the marble slabs, enriched by deep central grooves that gradually lessen towards the extremities: a detail revealing the authenticity of the solid marble, making it vibrate when struck by light.

Aves

AVET001 Aves Tavolo ovale 400x140x75 / Aves Table oval 400x140x75

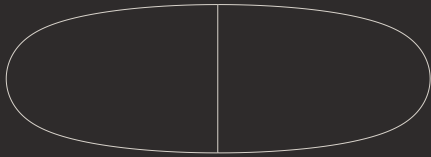

AVET002 Aves Tavolo rotondo D200x75 / Aves Table round D200x75

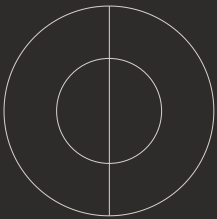

Islas

design by Draw Studio



Islas

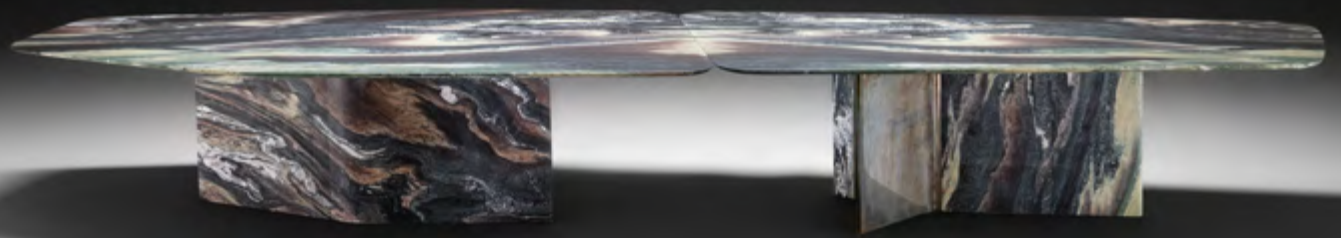

ISLAS Composizione principale / Main composition
Marmo Cipollino Misto, ottone brunito / Cipollino Misto
marble, burnished brass



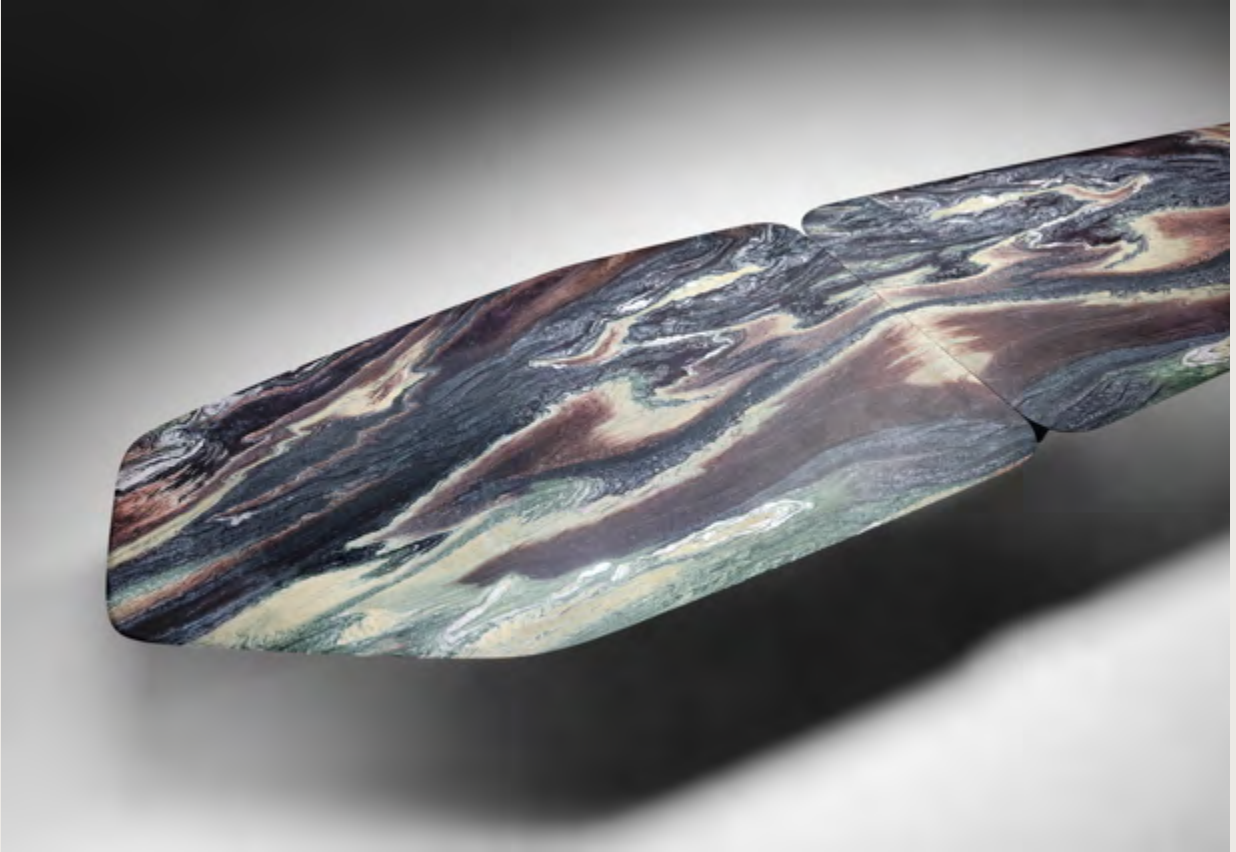

Islas

Tavolo, design by Draw Studio

ISLAS scardina la logica del tradizionale tavolo da pranzo: due elementi distinti, che vivono di un'estetica e una funzionalità propria, si uniscono per dare origine ad un pezzo unico, maestoso, scultoreo.

Come degli atolli in simbiosi tra loro, gli elementi che compongono il tavolo si uniscono tra loro per dare vita ad una geografia sempre diversa a seconda dello spazio che li circonda.

Il top ha una forma organica, affilata e leggera, disegnata da curve fluide e archi tesi, mentre la base è monolitica, composta da volumi di marmo ricavati dal pieno e cunei di metallo rastremati e finemente lavorati a mano.

Due le misure dei top: 285x145 cm e 320x160 cm.

Un progetto che si contraddistingue per un perpetuo gioco di dualità: due i pezzi accoppiati che danno vita alla collezione e a diverse combinazioni. Due i materiali impiegati: il marmo, materia d'elezione di NEUTRA, e il metallo, pregiato e ricercato nella lavorazione e nella finitura. Due le anime che hanno dato origine alla forma: una più decorativa, organica e spontanea, l'altra più misurata, rigorosa, e minimalista.

Table designed by Draw Studio

ISLAS redefines the conventional dining table concept by uniting two distinct components, each with its own design and purpose, to form a unique, extraordinary, and sculptural item.

Resembling atolls that coexist in harmony, these table elements merge to form a landscape that changes depending on the surrounding space.

The tabletop has an organic, sleek, and airy design, shaped by smooth curves and tight arcs, while the monolithic base is crafted from solid marble blocks and tapered, meticulously hand-finished metal wedges. The tabletop is available in two sizes: 285x145 cm and 320x160 cm.

This project is marked by a continuous interplay of dualities - two interconnected pieces that animate the collection and allow diverse configurations. The two materials chosen are marble, NEUTRA's preferred medium, and metal, valued for its exquisite craftsmanship and finish. The design is based on two concepts - one vibrant, organic, and spontaneous, the other measured, rigorous, and minimalist.

Islas

specifiche prodotto/
product specifications

ISLT001 Islas Tavolo 320x160x76 / Islas Table 320x160x76

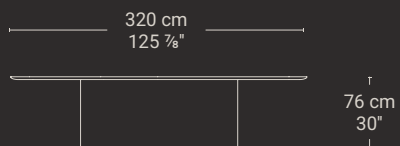

ISLT002 Islas Tavolo 285x145x76 / Islas Table 285x145x76



Islas

specifiche prodotto/
product specifications

ISLC003 Islas Composizione 1 / Islas Composition 1

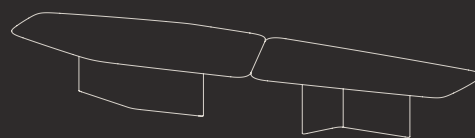
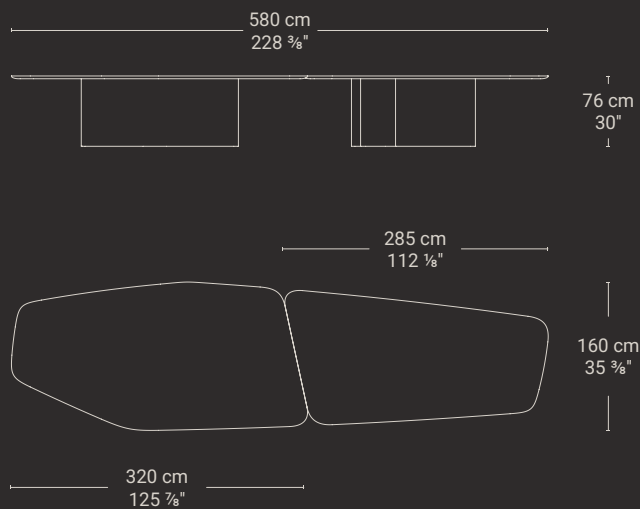

ISLC004 Islas Composizione 2 / Islas Composition 2

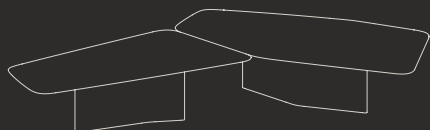

ISLC005 Islas Composizione 3 / Islas Composition 3

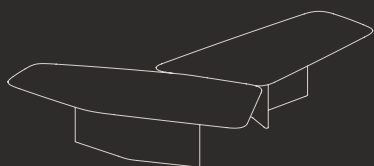

ISLC006 Islas Composizione 4 / Islas Composition 4

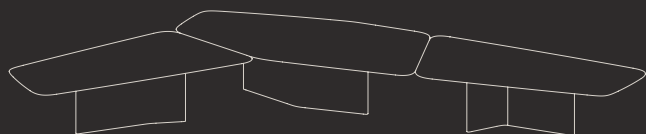

Leaf

design by Luca Martorano





LEAF Table
Marmo Travertino Romano /
Travertino Romano marble

Leaf

tavoli/tables

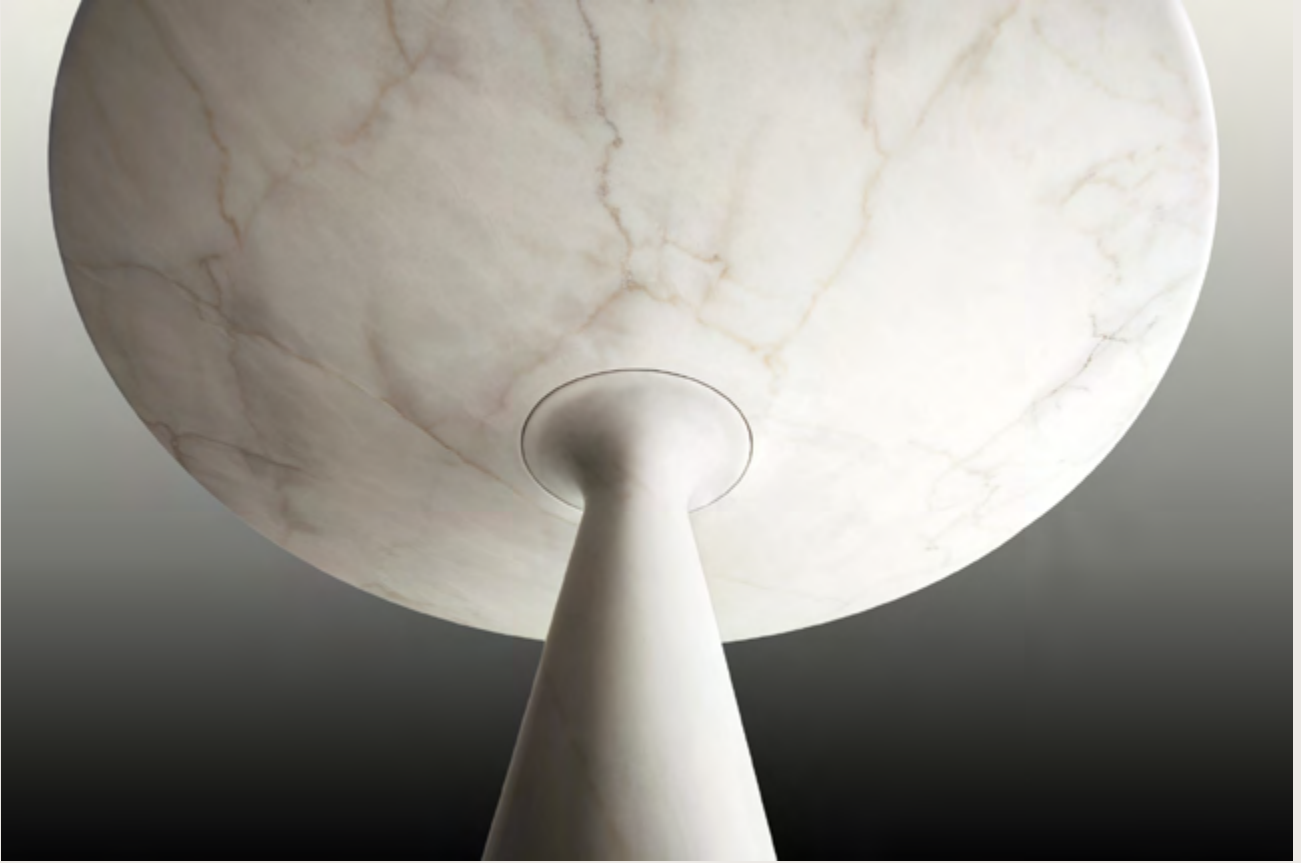

201

LEAF Table
Marmo Stargold / Stargold marble

Leaf

Tavolo, design by Luca Martorano

Leaf è un tavolo di design in pietra naturale nel quale la qualità della materia si eleva attraverso la leggerezza della forma. Un piano dallo spessore così sottile che sembra restare sospeso nell'aria come una foglia. Un esclusivo "gambo" in pietra naturale che dà energia alla struttura e all'ambiente. Un'opera unica di design, sintesi naturale fra estrema funzionalità e cura del dettaglio. Disponibile anche nella sua versione coffee table.

Table designed by Luca Martorano

Leaf is a natural stone designer table in which the quality of the material reaches its top, thanks to the light shape of the table. The top is so thin that seems to be suspended in the air, like a leaf. An exclusive natural stone "stem" gives energy to the structure and the environment. This is a unique piece of design, which is a natural combination of extreme functionality and attention to detail. Also available in the coffee table version.

Leaf

LEAT001 Leaf Tavolo D120x76
Leaf Table D120x76

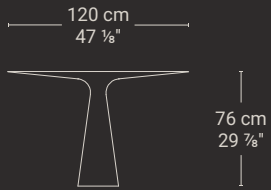

LEAT002 Leaf Tavolo D140x76
Leaf Table D140x76

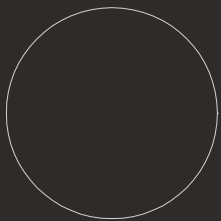
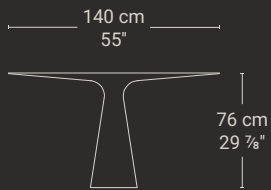

LEAT003 Leaf Tavolo D160x76
Leaf Table D160x76

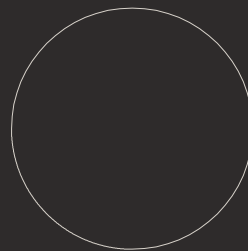
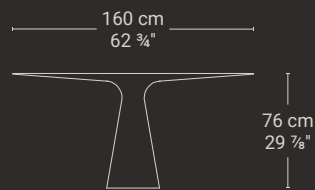

Minera

design by Zaha Hadid Architects





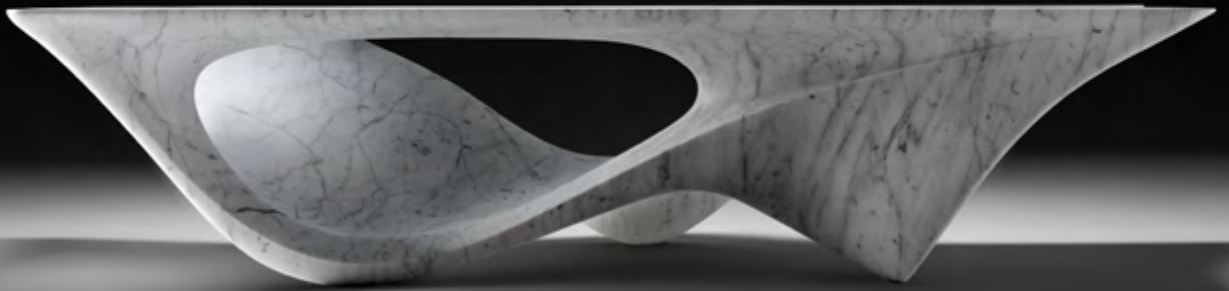

MINERA Marmo Bianco Carrara Statuarietto /
Bianco Carrara Statuarietto marble





Minera

Tavolo, design by Zaha Hadid Architects

EDIZIONE LIMITATA 8 PEZZI

Minera ridefinisce il concetto di tavolo da pranzo tradizionale attraverso una forma continua che, grazie ad un'impeccabile precisione artigianale, riunisce in sé forze contrastanti.

Le sue forme fluide, che esprimono l'effetto naturale dell'erosione, sono magistralmente plasmate da NEUTRA attraverso una delicata lavorazione che parte da un unico blocco di marmo.

Pensato per accogliere fino a 8 persone, il tavolo Minera è un pezzo esclusivo disponibile in un'edizione limitata di otto pezzi. Un prodotto scultoreo protagonista di un sofisticato dining.

Table designed by Zaha Hadid Architects

LIMITED EDITION 8 PIECES

Minera redefines the traditional dining table, emerging as a continuity of form that unites divergent forces with precision in craftsmanship.

Its fluid forms expressing the erosive forces of nature are skilfully carved by NEUTRA from a single block of marble.

Accommodating up to eight people, the Minera Table is available as an exclusive limited edition of eight pieces.

MINT001 Minera Tavolo 320x172x73
Minera Table 320x172x73

EDIZIONE LIMITATA 8 PZ. / LIMITED EDITION 8 PCS.

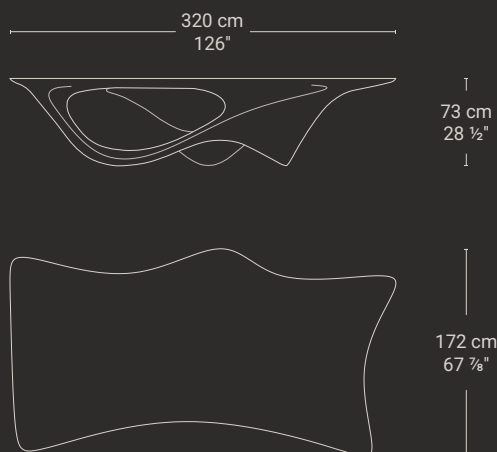

*La collezione Minera è disponibile su richiesta in diversi marmi, previa verifica tecnica.
The Minera collection is available on request in different marbles, after technical testing.*

Theia

design by STUDIOPIVA





Theia



tavoli/tables

212

THEIA Tavolo / Table
Bronzo, Marmo Patagonia / Bronze,
Patagonia marble

Theia

Tavoli, design by STUDIOPIVA

La forma circolare del piano è l'elemento condiviso da tutti i modelli della serie Theia: tavoli, tavolini e sgabelli, che evocano nel nome l'omonimo pianeta che 4 miliardi di anni fa andò in collisione con la Terra (il cosiddetto "impatto gigante"), producendo la formazione del nostro unico satellite, la Luna. Questo evento galattico ed originario è rievocato dalle forme essenziali, quasi lunari, dei piani degli arredi Theia.

Tutti gli elementi della collezione, utilizzabili anche in contesti outdoor, sono caratterizzati da una struttura in fusione di bronzo costituita da un piano ad anello da cui si allungano le tre gambe (quattro nella versione tavolo da pranzo con diam. 180 cm); alla struttura, sagomata ad arte, aderiscono, quasi in simbiosi, gli inserti in marmo delle gambe e il piano - in marmo nel caso di tavoli e tavolini, rivestito in pelle Nabuk per gli sgabelli, disponibile in altre varianti di pelle o tessuto.

Tables designed by STUDIOPIVA

The top circular shape is the element shared by all Theia range models. Tables, coffee tables and stools, with a name which evokes the planet that collided with the Earth four billion years ago (the "giant impact"), creating the Moon. This galactic and original event is suggested by the essential, almost lunar shapes of the tops of Theia furnishings.

The collection elements, which can be used outdoors, feature a cast bronze structure consisting of a ring-shaped top from which three legs (four in the dining table version with a 180 cm diameter) extend. The legs' marble inserts symbiotically adhere to the artfully shaped structure. The tables and coffee tables' top are in marble, the stools covered in Nabuk leather, and are available in other leather or fabric versions.

Theia

THET001 Theia Tavolo D140x75 Bronzo
Theia Table D140x75 Bronze

THET004 Theia Tavolo D140x75 Alluminio
Theia Table D140x75 Aluminium

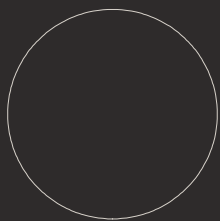
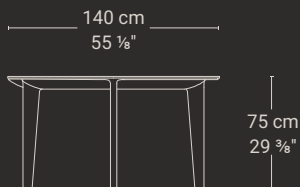

THET002 Theia Tavolo D160x75 Bronzo
Theia Table D160x75 Bronze

THET005 Theia Tavolo D160x75 Alluminio
Theia Table D160x75 Aluminium

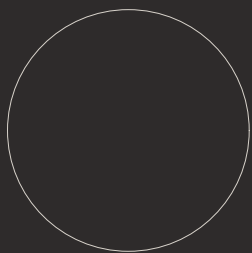
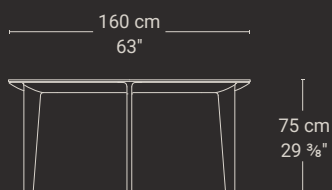

THET003 Theia Tavolo D180x75 Bronzo
Theia Table D180x75 Bronze

THET006 Theia Tavolo D180x75 Alluminio
Theia Table D180x75 Aluminium

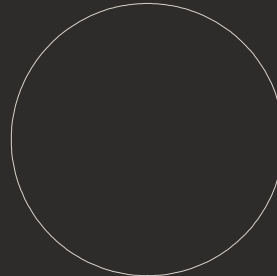
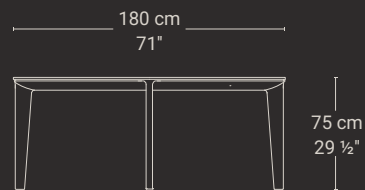

NEUTRA
Outdoor

La Grande Muraglia Outdoor

design by Mario Bellini





LGM Poltrona Outdoor / Outdoor Armchair
Marmo Travertino Silver, Tessuto Outdoor Altai
Corallo / Travertino Silver marble, Outdoor Fabric
Altai Corallo

La Grande Muraglia Outdoor

Collezione di divani e sedute outdoor
by Mario Bellini

I nuovi elementi della collezione includono un divano tre posti, un divano due posti, una poltrona e una chaise longue, progettati per offrire comfort e stile nel vivere open air. La scelta dei materiali per l'imbottitura sfoderabile, - poliuretano impermeabilizzato rivestito con fibra resinata e fodera in poliestere idrorepellente - e il rivestimento in tessuto dei cuscini in polipropilene impermeabile 100% riciclabile, è altrettanto imprescindibile: NEUTRA propone cinque varianti di tessuto, Zaffiro, Matcha, Corallo, Terracotta e Tabacco, e garantisce una personalizzazione su richiesta, anche relativamente alla scelta della pietra della struttura, per adattarsi a ogni gusto e ambiente. La cuscinatura è facilmente rimovibile dalla struttura qualora la si volesse conservare in un luogo protetto e asciutto nei mesi invernali, lasciando a vista la struttura architettonica che esprime anche in questa versione la sua forza scultorea.

Outdoor sofa and seating collection designed by
Mario Bellini

New elements in the collection include a three-seater sofa, a two-seater sofa, an armchair and a chaise longue, designed to offer comfort and style in open-air living. The choice of materials for the removable upholstery, - waterproof polyurethane covered with resin-coated fiber and water-repellent polyester lining - and the fabric upholstery 100% recyclable of the waterproof polypropylene cushions is equally essential: NEUTRA offers five fabric variants, Zaffiro, Matcha, Corallo, Terracotta and Tabacco, and guarantees customization upon request, even regarding the choice of stone for the structure, to match every style and atmosphere. The cushioning is easily removable from the structure in case it is necessary to store it in a protected and dry place during the winter months, leaving the architectural structure visible, which expresses its sculptural force in this version as well.

specifiche prodotto/
product specifications

La Grande Muraglia Outdoor

LAP007

LGM Poltrona Outdoor 129x95x91
LGM Outdoor Armchair 129x95x91

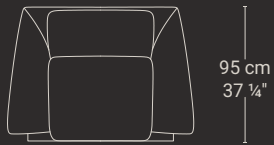
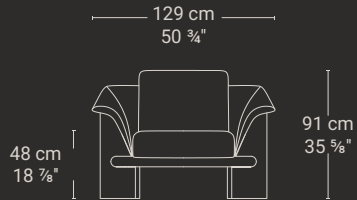

specifiche prodotto/
product specifications

Micelio Outdoor

design by atelier oï

tavolini/small tables



MICELIO Outdoor
Composizione 3 top /
Composition 3 tops
Marmo Travertino Silver /
Travertino Silver marble



Micelio Outdoor

Sistema componibile di tavoli bassi,
design by atelier oi

Il sistema componibile di tavoli bassi Micelio è un progetto modulare che rivela un paesaggio organico e, nel nome, l'ispirazione all'apparato vegetativo dei funghi.

Caratterizzato da una forma unica nel suo genere, il progetto nasce dalla combinazione di due elementi scolpiti distinti che permettono di creare una serie infinita di forme diverse, connotando con dinamismo l'orizzonte domestico.

La lunghezza e la profondità delle composizioni sono variabili, per un'altezza di 42/63 cm.

All'insegna della versatilità, i piani del tavolino e gli elementi a ponte si combinano in un dinamico gioco per creare soluzioni di appoggio o di seduta, compatte o più allargate, per adattarsi alle esigenze più diverse sia in ambito domestico che hospitality.

Grazie alla sua forma sinuosa, la pietra naturale, valorizzata dalle irregolari venature che ne accentuano il fascino, arriva ad esprimere sensazioni di morbidezza in un elegante contrasto con la durezza della pietra.

Modular low table system designed by atelier oi

The modular low table system Micelio reveals an organic landscape and draws its name from the vegetative structure of mushrooms.

The design, distinguished by its unique form, combines two different sculpted elements that enable endless different shapes, dynamically defining the domestic horizon.

The compositions can vary in length and depth, with a height of 42/63 cm.

Embodying versatility, the table tops and the bridge elements interact dynamically to create compact or expanded support or seating solutions which adapt to different residential and hospitality needs.

With its flowing shape the natural stone is enhanced by the irregular veins that emphasise its charm. It expresses a sense of softness in stylish contrast with the stone's hardness.

Micelio Outdoor

MICC004 Micelio Composizione 2 top
Micelio Composition 2 tops

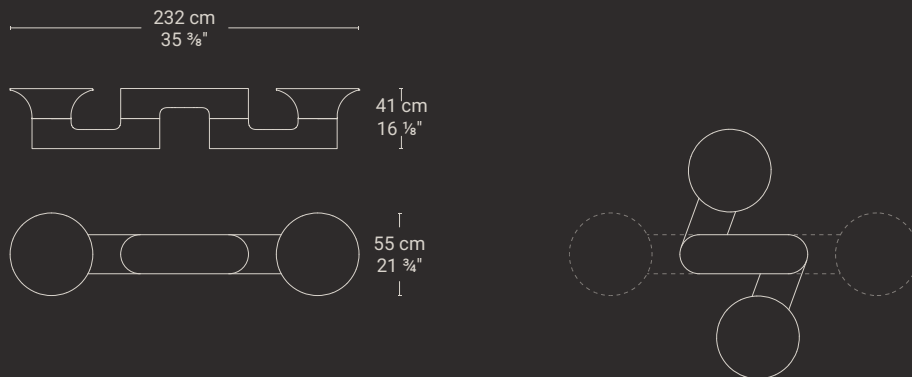

MICC005 Micelio Composizione 3 top
Micelio Composition 3 tops

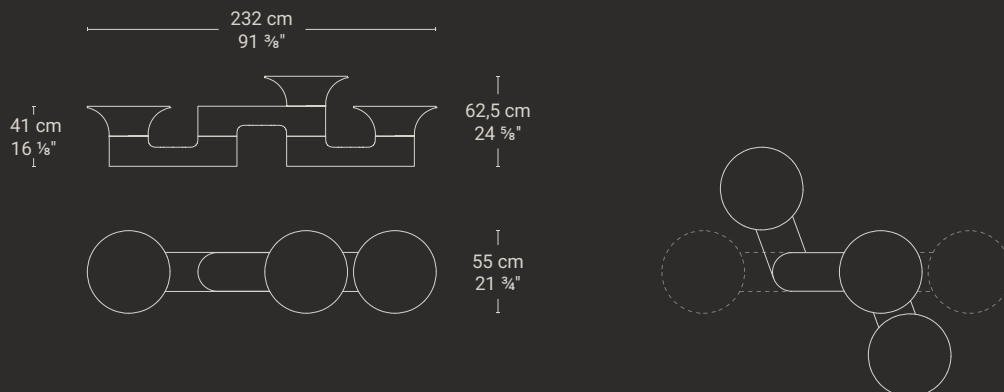

Coronae

design by Migliore+Servetto





Coronae

tavolini/small tables



CORONAE D130x38 Coffee Table Marble Base /
Coffee Table Base Marmo
Marmo Travertino Romano / Travertino Romano
marble

Coronae



Coronae

tavolini/small tables

228



CORONAE D60x42 Coffee Table Marble Base /
Coffee Table Base Marmo
Marmo Travertino Romano / Travertino Romano
marble

Coronae

Coffee tables, design by Migliore + Servetto

L'essenza dell'elegante semplicità rivive nei coffee table Coronae. L'azienda esplora il concetto di minimalismo organico attraverso forme equilibrate e pulite unite a dettagli originali applicati al marmo. A connotare infatti questi complementi è la lavorazione del piano, realizzato con un bordo inclinato e asimmetrico, così da conferire un effetto di dinamicità e movimento, soprattutto in combinazioni multiple che affiancano le differenti misure disponibili (con diametro 60, 90, 130 cm) L'asimmetria è poi ripresa nella base, a tronco di cono che culmina in un cilindro. Coronae è quindi un oggetto estremamente sofisticato nella sua essenzialità.

Coffee tables designed by Migliore + Servetto

The essence of elegance in its simplicity is brought back to life with the Coronae coffee tables. The company explores the concept of organic minimalism through balanced, clean shapes combined with original details applied to marble, characterizing the workmanship of the tabletop. Its slanting and asymmetrical edge gives a sense of dynamism and movement, even more so in the multiple combinations in the different sizes available (diameter 60, 90 and 130 cm). The asymmetry is recaptured in the base, a truncated conical shape culminating in a cylinder. Coronae is, without doubt, an extremely sophisticated item in its essence.

Coronae

CORC001 Coronae Coffee Table Base Marmo D130x38
Coronae Coffee Table Marble Base D130x38

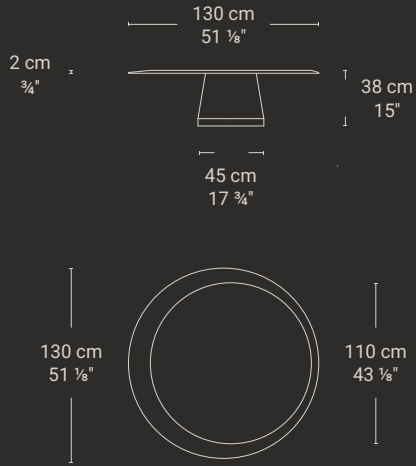

CORC002 Coronae Coffee Table Base Marmo D60x42
Coronae Coffee Table Marble Base D60x42

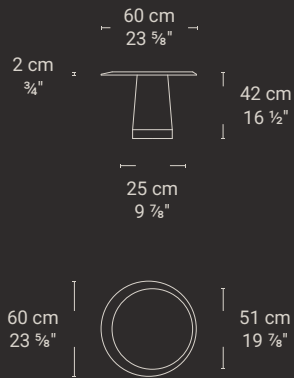

Coronae

CORC005 Coronae Coffee Table Base Marmo D90x47
Coronae Coffee Table Marble Base D90x47

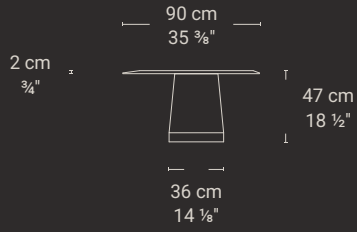

specifiche prodotto/
product specifications

Leaf

design by Luca Martorano





LEAF Coffee table
Marmo Travertino Romano /
Travertino Romano marble

Leaf

Coffee table, design by Luca Martorano

Leaf è un tavolino di design in pietra naturale nel quale la qualità della materia si eleva attraverso la leggerezza della forma. Un piano dallo spessore così sottile che sembra restare sospeso nell'aria come una foglia. Un esclusivo "gambo" in pietra naturale che dà energia alla struttura e all'ambiente. Un'opera unica di design, sintesi naturale fra estrema funzionalità e cura del dettaglio. Disponibile anche nella sua versione tavolo.

Coffee Table designed by Luca Martorano

Leaf is a natural stone designer coffee table in which the quality of the material reaches its top, thanks to the light shape of the table. The top is so thin that seems to be suspended in the air, like a leaf. An exclusive natural stone "stem" gives energy to the structure and the environment. This is a unique piece of design, which is a natural combination of extreme functionality and attention to detail. Also available in the table version.

Leaf

LEAC004 Leaf Coffee Table D45x61

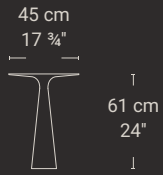

LEAC005 Leaf Coffee Table D57x51

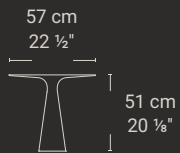

LEAC006 Leaf Coffee Table D70x39

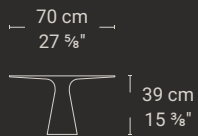

Micelio Outdoor

design by atelier oï







MICELIO Outdoor Seduta doppia bassa / Double Seat low
Marmo Bianco Carrara Statuarietto, tessuto Outdoor Altai
Corallo / Bianco Carrara Statuarietto Marble, Outdoor Fabric
Altai Corallo

Micelio Outdoor

Sistema di sedute modulare, design by atelier oï

Micelio è un elemento vivo, in costante evoluzione. Cresce e si trasforma nello spazio. Nato dal concept che ha dato forma dall'omonima collezione di coffee table, questo sistema di sedute modulare si ispira alla natura invisibile delle catene miceliali, esplorando così il tema della connessione e del fluire delle forme. La natura organica della base si presta a configurazioni infinite, e accoglie le poltrone girevoli in pelle che ne amplificano il senso di movimento e fluidità. La rotazione delle morbide sedute, che possono vivere singolarmente o in coppia, creano un andamento ritmato, un'interazione spontanea tra corpi e spazio.

Modular seating system designed by atelier oï

Micelio is an ever-evolving living element that grows and transforms within spaces. Born from the concept of its namesake coffee table collection, this modular seating system is inspired by the invisible nature of mycelial chains, exploring the theme of connection and the flow of forms. Infinite configurations become possible thanks to the organic nature of the base, with leather swivel chairs emphasizing the sense of movement and fluidity. The rotation of the soft seats, which can live individually or in pairs, creates a spontaneous interaction between the body and space in a rhythmic pattern.

Micelio Outdoor

MICC006 Micelio Seduta singola 167x70x73
Micelio Seat single 167x70x73

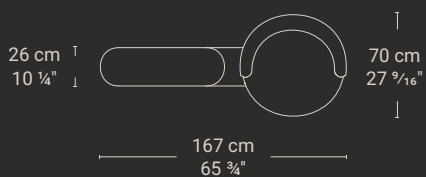

MICC007 Micelio Seduta doppia bassa 249x70x73
Micelio Seat double low 249x70x73

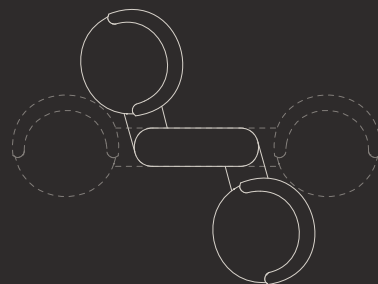
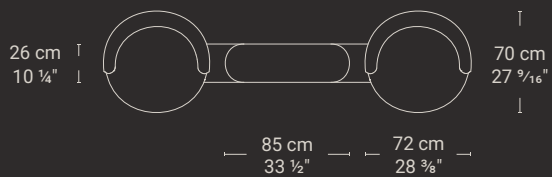
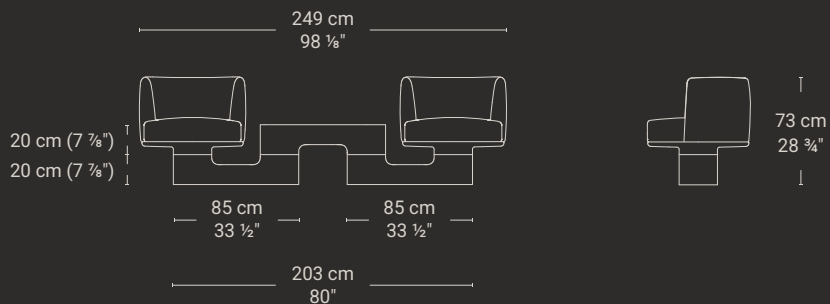

Micelio Outdoor

MICC008 Micelio Seduta doppia bassa 249x70x73
Micelio Seat double high 249x70x73

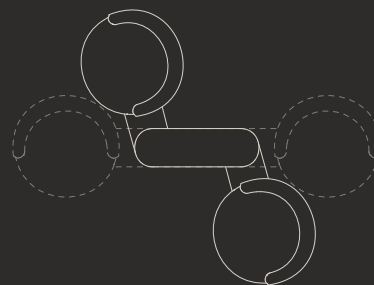
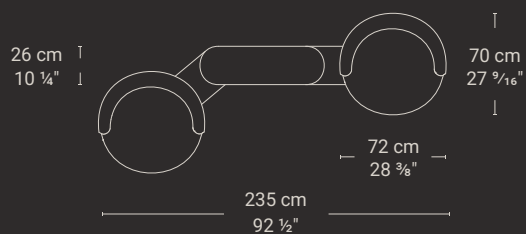
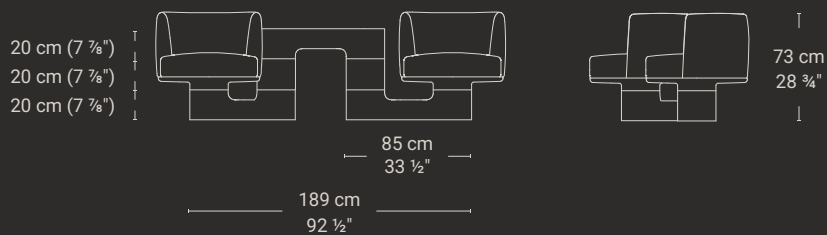

specifiche prodotto/
product specifications

La Grande Muraglia Outdoor

design by Mario Bellini







LGM Divano Outdoor 3P / Outdoor Sofa 3S
Marmo Travertino Silver, Tessuto Outdoor Altai
Matcha / Travertino Silver marble, Outdoor Fabric
Altai Matcha

L'inedita versione "La Grande Muraglia Outdoor", un unicum che vede per la prima volta una collezione di divani e sedute outdoor in marmo firmata da un grande maestro e ideata nel 1981, si distingue per una struttura in Travertino Silver, che aggiunge un tocco di raffinata sobrietà ad ogni ambiente esterno. La scelta di questa pietra naturale di colorazione intensa e porosità elevata, tagliata al contro per valorizzarne le venature uniche e trattata con finitura spazzolata a poro aperto, rende ogni pezzo unico e senza tempo, oltre a garantire una durevolezza eccezionale.



LGM Outdoor Chaise longue
Marmo Travertino Silver, Tessuto Outdoor Altai
Terracotta / Travertino Silver marble, Outdoor
Fabric Altai Terracotta



LGM Outdoor Chaise longue
Marmo Travertino Silver, Tessuto Outdoor Altai
Zaffiro / Travertino Silver marble, Outdoor Fabric
Altai Zaffiro

The unprecedented "La Grande Muraglia Outdoor" version, a unicum featuring for the first time a marble outdoor sofa and seating collection signed by a great master and conceived back in 1981, is distinguished by a Silver travertine structure that adds a touch of refined sobriety to any exterior ambience. The choice of this natural stone of intense coloring and high porosity, cut to the counter to enhance its unique veining and treated with an open-pore brushed finish, makes each piece unique and timeless, as well as ensuring exceptional durability.





sedute_outdoor/outdoor_seating

248

LGM Divano Outdoor 2P / Outdoor Sofa 2S
Marmo Travertino Silver, Tessuto Outdoor Altai
Tabacco / Travertino Silver marble, Outdoor Fabric
Altai Tabacco

La Grande Muraglia Outdoor

Collezione di divani e sedute outdoor
by Mario Bellini

I nuovi elementi della collezione includono un divano tre posti, un divano due posti, una poltrona e una chaise longue, progettati per offrire comfort e stile nel vivere open air. La scelta dei materiali per l'imbottitura sfoderabile, - poliuretano impermeabilizzato rivestito con fibra resinata e fodera in poliestere idrorepellente - e il rivestimento in tessuto dei cuscini in polipropilene impermeabile 100% riciclabile, è altrettanto imprescindibile: NEUTRA propone cinque varianti di tessuto, Zaffiro, Matcha, Corallo, Terracotta e Tabacco, e garantisce una personalizzazione su richiesta, anche relativamente alla scelta della pietra della struttura, per adattarsi a ogni gusto e ambiente. La cuscinatura è facilmente rimovibile dalla struttura qualora la si volesse conservare in un luogo protetto e asciutto nei mesi invernali, lasciando a vista la struttura architettonica che esprime anche in questa versione la sua forza scultorea.

Outdoor sofa and seating collection designed by
Mario Bellini

New elements in the collection include a three-seater sofa, a two-seater sofa, an armchair and a chaise longue, designed to offer comfort and style in open-air living. The choice of materials for the removable upholstery, - waterproof polyurethane covered with resin-coated fiber and water-repellent polyester lining - and the fabric upholstery 100% recyclable of the waterproof polypropylene cushions is equally essential: NEUTRA offers five fabric variants, Zaffiro, Matcha, Corallo, Terracotta and Tabacco, and guarantees customization upon request, even regarding the choice of stone for the structure, to match every style and atmosphere. The cushioning is easily removable from the structure in case it is necessary to store it in a protected and dry place during the winter months, leaving the architectural structure visible, which expresses its sculptural force in this version as well.

La Grande Muraglia Outdoor

specifiche prodotto/
product specifications

LAD005 LGM Divano Outdoor 3P 305x95x91
LGM Outdoor Sofa 3S 305x95x91

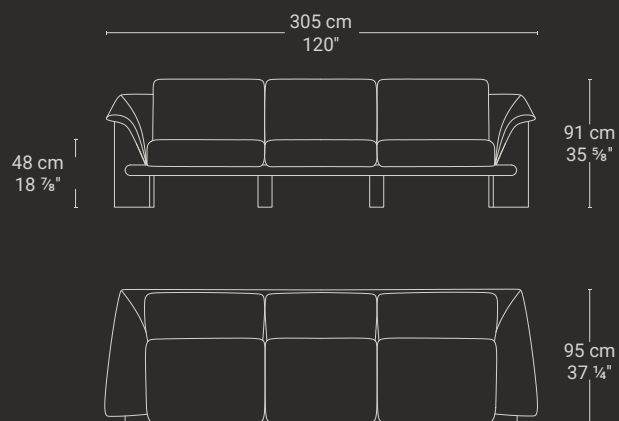

LAD006 LGM Divano Outdoor 2P 224x95x91
LGM Outdoor Sofa 2S 224x95x91

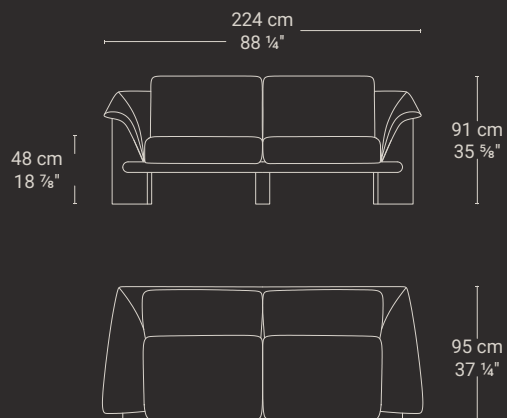

La Grande Muraglia Outdoor

LAC008 LGM Chaise longue Outdoor 225x120x95
LGM Outdoor Chaise longue 225x120x95

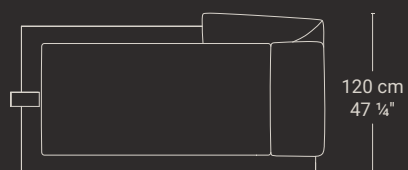
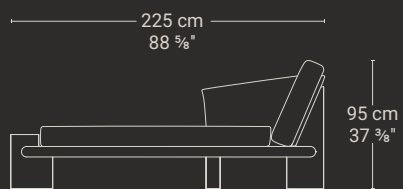

specifiche prodotto/
product specifications

Leaf

design by Luca Martorano





LEAF Table
Marmo Travertino Romano /
Travertino Romano marble

Leaf

Tavolo, design by Luca Martorano

Leaf è un tavolo di design in pietra naturale nel quale la qualità della materia si eleva attraverso la leggerezza della forma. Un piano dallo spessore così sottile che sembra restare sospeso nell'aria come una foglia. Un esclusivo "gambo" in pietra naturale che dà energia alla struttura e all'ambiente. Un'opera unica di design, sintesi naturale fra estrema funzionalità e cura del dettaglio. Disponibile anche nella sua versione coffee table.

Table designed by Luca Martorano

Leaf is a natural stone designer table in which the quality of the material reaches its top, thanks to the light shape of the table. The top is so thin that seems to be suspended in the air, like a leaf. An exclusive natural stone "stem" gives energy to the structure and the environment. This is a unique piece of design, which is a natural combination of extreme functionality and attention to detail. Also available in the coffee table version.

Leaf

LEAT001 Leaf Tavolo D120x76
Leaf Table D120x76

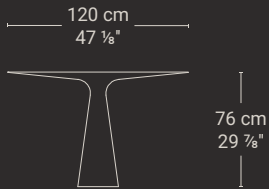

LEAT002 Leaf Tavolo D140x76
Leaf Table D140x76

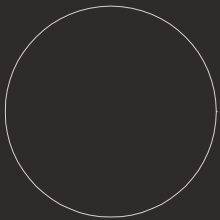
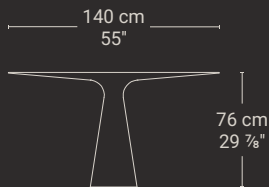

LEAT003 Leaf Tavolo D160x76
Leaf Table D160x76

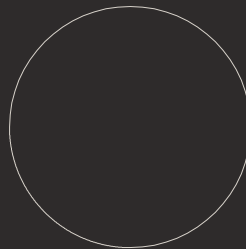
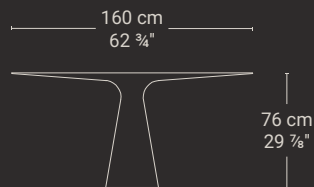

NEUTRA
Lighting

Eos

design by Draw Studio





EOS Marmo Cipollino Crema, ottone
brunito /
Cipollino Crema marble, burnished
brass details

Eos

Lampada a sospensione, design by Draw Studio

La lampada a sospensione EOS, dal nome della dea greca dell'alba, è un omaggio alla colonna dei templi greci, la cui forma archetipica fonde indissolubilmente estetica e funzione. Le scanalature che la caratterizzano, oltre che elementi decorativi, rappresentano una soluzione ottica e percettiva per snellire il volume cilindrico, esaltandone l'altezza e la verticalità. Conferiscono anche plasticità alla forma, facendo vibrare la sua superficie quando colpita dalla luce indiretta. Un gioco di chiaro-scuro ancora più marcato quando numerosi pendenti vengono raggruppati insieme a scandire lo spazio proprio come le colonne di un tempio indorato dalla luce dell'alba.

Una micro-architettura aerea, una scultura di materia e luce.

Pendant lamp designed by Draw Studio

The EOS pendant lamp, inspired by the Greek goddess of dawn, pays homage to the classical columns of Greek temples. The columns' archetypal shape inextricably blends aesthetics and function.

Its distinctive grooves provide an ornamental feature and a visual and tactile solution to refine its cylindrical shape, amplifying its stature and verticality. These grooves provide plasticity to the shape making its surface resonate when struck by diffused light.

When arranged in groups, these pendants create a light and darkness dramatic effect, reminiscent of temple columns bathed in the early morning light.

It is an aerial micro-architecture, a sculpture of matter and light.

Eos

EOSL001

Eos Lampada a sospensione D10x72
Eos Pendant lamp D10x72

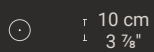
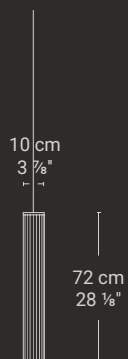

Esempi di composizione / Examples of composition



specifiche prodotto/
product specifications

Lente

design by Migliore+Servetto







LENTE Lampada da Terra / Floor Lamp
Marmo Absolute Black, vetro fuso nero, calamina /
Absolute Black marble, Black Molten Glass, Calamina

LENTE Lampada da Tavolo / Table Lamp
Marmo Tobacco Brown, vetro fuso ambrato / Tobacco
Brown marble, Amber Molten Glass



Lente

Lampada, design by Migliore+Servetto

LAMPADA DA TERRA EDIZIONE LIMITATA 30 PEZZI

Un grande occhio di luce che esplora lo spazio, catturando e diffondendo bagliori attraverso la sua doppia lente. La lampada Lente si distingue per la purezza del segno e per il suo effetto etereo: il vetro fuso, attraversato dalla luce, amplifica la percezione di leggerezza, mentre la base in marmo le conferisce un senso di radicata stabilità. Nella versione da terra si impone con una presenza scenografica, quasi teatrale; nella variante da tavolo, invece, diventa un compagno silenzioso, perfetto per definire atmosfere intime e raccolte.

Lamp designed by Migliore + Servetto

FLOOR LAMP LIMITED EDITION 30 PIECES

A large eye of light exploring space, Lente captures and diffuses the glow through its lens. It is distinguished by the purity of its design and for its ethereal effect: molten glass, through which the light passes, emphasizes the perception of lightness while the marble base gives it a sense of deeply rooted stability. In the floor version it's imposing, with its scenographic and almost theatrical presence, while the desk version becomes a perfect silent companion, setting the mood for intimate and cosy situations.

specifiche prodotto/
product specifications

Lente

LENL001 Lente Lampada da Tavolo D62x25x72
Lente Table Lamp D62x25x72

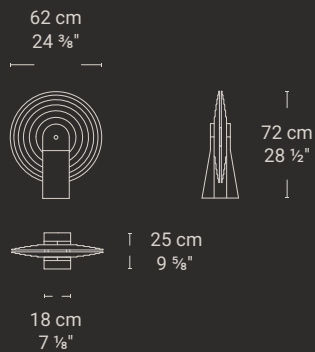

LENL002 Lente Lampada da Terra D120x44x150
Lente Floor Lamp D120x44x150
EDIZIONE LIMITATA 30 PZ. / LIMITED EDITION 30 PCS.

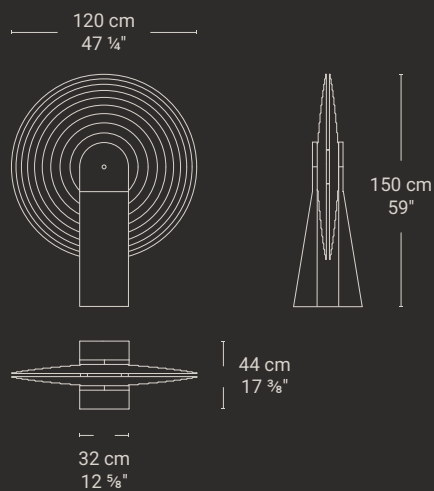

Meti

design by STUDIOPIVA







METI Lampada a parete / Wall Lamp
Marmo Verde Alpi / Verde Alpi marble

Meti

Lampade, design by STUDIOPIVA

La serie è basata su un unico modello di lampada circolare, declinata in diverse dimensioni e in differenti materiali – marmi e onici – che ne modificano l'essenza e l'effetto luminoso. Meti è costituita da un disco monolitico di marmo o onice perfettamente sagomato, che si innesta sulla parete o a soffitto, grazie a un cilindro metallico in cui è contenuta la sorgente luminosa, posto sul retro. Il cilindro nascosto consente al disco litico di mantenere una leggera distanza dalla parete stessa.

Nella versione realizzata in marmo, la luce totalmente schermata dal disco viene emessa in maniera indiretta sulla parete circostante, con un effetto simile a quello di un'eclisse. La versione realizzata in onice, invece, permette alla luce di filtrare attraverso il materiale stesso, generando in tal modo un effetto luminoso che ricorda la sagoma della Luna. La forma pura di Meti e le suggestioni luminose astratte e 'spaziali' che genera sulla parete richiamano la figura di Methis, potente dea della mitologia greca, madre di Atena, a cui veniva associata l'intelligenza che tutto muta e trasforma.

Lamps designed by STUDIOPIVA

The series is based on a single circular lamp model, made of different marble and onyx materials that modify its essence and luminous effect. Meti consists of a perfectly shaped monolithic disc of marble or onyx which is placed on the wall or ceiling, using a metal cylinder placed on the back, where the light source is contained. The hidden cylinder allows the stone disc to maintain a slight distance from the wall.

The light in the marble version is screened by the disc and emitted indirectly onto the surrounding wall with an eclipse effect.

The onyx version allows light to filter through the material, generating a luminous effect reminiscent of the moon's silhouette.

The Meti pure form and abstract and "spatial" light images it generates on the wall recall Methis, the powerful Greek goddess, mother of Athena, who was associated with the intelligence that changes and transforms everything.

Meti

METL001 Meti Lampada a parete D40
Meti Wall Lamp D40

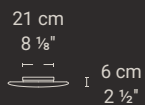

METL002 Meti Lampada a parete D60
Meti Wall Lamp D60

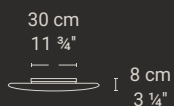
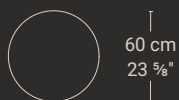

METL003 Meti Lampada a parete D80
Meti Wall Lamp D80

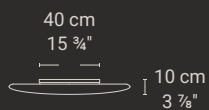
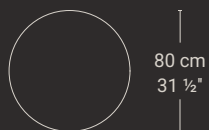

Révérence

design by atelier oï





Révérence



REVERENCE Lampada da Terra / Floor Lamp
Marmo Bianco Carrara Statuarietto / Bianco Carrara
Statuarietto marble

Révérence



RÉVÉRENCE Lampada da Tavolo / Table Lamp
Marmo Bianco Carrara Statuarietto / Bianco Carrara
Statuarietto marble

Révérence



RÉVÉRENCE Lampada da Tavolo small / Table Lamp small
Marmo Oyster White / Oyster White marble

Révérance

Lampada, design by atelier oi

RÉVÉRENCE è una sofisticata lampada-scultura, nella versione da terra e da tavolo, che esplora il dualismo tra luce e pietra, che si combinano all'unisono, in una dinamica composizione di volumi.

Prende il nome dalla parola francese "révérence", che significa "inchino", ad indicare il movimento gentile che compie cambiando la sua inclinazione per orientare il fascio di luce.

Il concetto di dualità si ritrova anche nella struttura della lampada composta da due elementi in marmo, la base e il diffusore, svuotati al loro interno per un gioco di pieni e vuoti e uniti tra loro da un raffinato giunto in ottone bronzato.

Il diffusore può essere orientato a piacimento consentendo una diversa distribuzione della luce, a seconda della collocazione.

Anche la nuova versione Révérence Small, ha due diverse anime: se collocata in posizione verticale, forma un'alcova di marmo che cattura la luce creando un'atmosfera di contemplazione; se inclinata, si trasforma in una lampada da tavolo con un'illuminazione puntuale, dondolando dolcemente sulla base grazie a uno studio preciso del suo centro di gravità.

Lamp designed by atelier oi

RÉVÉRENCE is an elegant lamp-sculpture, available in floor and table models, that explores the duality of light and stone. These elements merge harmoniously in a vibrant arrangement of shapes.

Named after the French word "révérence" meaning "bow", the lamp signifies the subtle motion it makes as it adjusts its angle to direct the light beam.

The lamp's structure, which is composed of two marble elements - base and diffuser, embodies the concept of duality. These hollowed out elements create an interplay of full and empty spaces, and are united by a sophisticated bronzed brass joint.

The diffuser can be adjusted as desired, allowing for a different light distribution depending on its position.

Even the new Révérence Small reveals a double soul: upright, it forms a marble alcove, capturing the light and creating a contemplative atmosphere; tilted, it is transformed into a table lamp with pinpoint lighting, gently rocking on its base thanks to a precise study of its center of gravity.

Révérance

specifiche prodotto/
product specifications

REVL001 Révérence Lampada da tavolo D16x75
Révérence Table Lamp D16x75

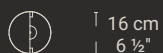
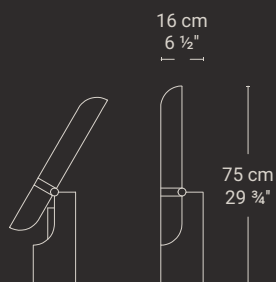

REVL002 Révérence Lampada terra D24x145
Révérence Floor lamp D24x145

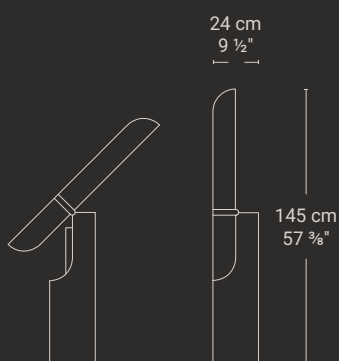

REVL003 Révérence Lampada da Tavolo small 13x22x50
Révérence Table Lamp small 13x22x50

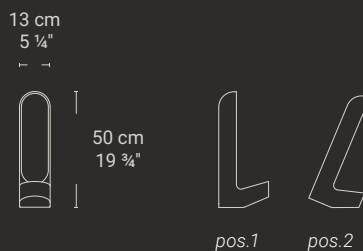

Strobilo

design by Migliore+Servetto





Strobilo



STROBILO Lampada da Tavolo / Table Lamp D50x345
Marmo Rosso Lepanto, metallo nuvolato opaco Silver, vetro /
Rosso Lepanto marble, Matt Cloudy Silver Metal, Glass

STROBILO Lampada da Terra / Floor Lamp D60x55
Marmo Verde Borgogna, metallo verde lucido, vetro
Verde Borgogna marble, Green Glossy Metal, Glass



Strobilo



STROBILO Lampada da Terra / Floor Lamp D60x55
Marmo Tobacco Brown, metallo marrone lucido, vetro /
Tobacco Brown marble, Brown Glossy Metal, Glass

STROBILO Lampada da Tavolo / Table Lamp D50x34
Marmo Sodalite Blu, calamina, vetro / Sodalite Blu
marble, Calamina, Glass

Strobilo

Lampada, design by Migliore+Servetto

Strobilo omaggia la forza degli elementi naturali. Con la sua forma evocativa di un vortice d'acqua che modella la roccia, lascia emergere delicatamente la luce dal basamento cilindrico in vetro per rifrangersi nel disco superiore, realizzato in marmo. La lampada genera un'atmosfera morbida ed elegante, interagendo delicatamente con lo spazio quanto con l'illuminazione naturale, in un gioco di riflessi e armonia. Versione da tavolo disponibile in due misure di diametro.

Lamp designed by Migliore + Servetto

Strobilo pays tribute to the power of natural elements. Its shape recalls the vortex of water shaping the rock, light gently emerging from its cylindrical glass base diverging in the marble upper disc. The lamp generates a soft and elegant atmosphere, delicately interacting with the space and natural light in a harmonious play of reflections. Table version available in two diameters.

Strobilo

STR001 Strobilo Lampada da Tavolo D50x34
Strobilo Table Lamp D50x34



STR002 Strobilo Lampada da Tavolo D60x55
Strobilo Table Lamp D60x55

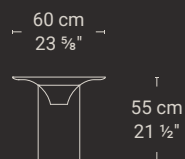

NEUTRA
Bathroom

Majesté

design by Monica Armani





Majesté



MAJESTÉ Lavabo Freestanding / Freestanding Basin
Marmo Verde Borgogna / Verde Borgogna marble
Accessori Zucchetti / Zucchetti accessories



Majesté

lavabi/basins



Majesté

Lavabo, design by Monica Armani

Majesté si compone di una vasca e un lavabo monolitici, accompagnati da un maestoso specchio (tondo oppure ovale). La collezione modella la pietra sul concetto di regalità, una visione che trasforma il bagno in un regno esclusivo e senza tempo. Le forme scultoree, morbide e avvolgenti, rivelano la bellezza della materia. Proprio la preziosità del marmo ha ispirato Monica Armani ad immaginare la vasca e il lavabo dotati di un colletto "sparato", tipico degli abiti regali dei nobili, che diventa un elemento di accoglienza, un invito a entrare in un ambiente dove l'eleganza si fonde con la forza primordiale della natura.

Ogni superficie, ogni curva racconta una storia di maestosità, e ogni dettaglio riflette la lucentezza intramontabile di una pietra che si lascia modellare dal tempo senza mai perdere la forza.

Freestanding sink designed by Monica Armani

The Majesté collection is composed of a monolithic bathtub and washbasin, accompanied by a majestic mirror (round or oval). A vision born from an encounter between stone and the concept of royalty, the bathroom is transformed into an exclusive and timeless realm. Soft and enveloping sculptural forms appear to emerge from the stone itself, as if the material had chosen to unveil itself under the sign of beauty. Inspired by the preciousness of marble, Monica Armani imagined a bathtub and washbasin with a 'shot' collar, typical of the royal robes worn by nobility, as a welcoming element and invitation to enter an environment where elegance merges with the primordial force of nature. Every surface, every curve tells a majestic story, with each single detail reflecting the timeless brilliance of a stone that lets itself be shaped by time without ever losing its strength.

Majesté

MAJB002 Majestè Lavabo Freestanding 81x61x88
Majesté Freestanding Basin 81x61x88

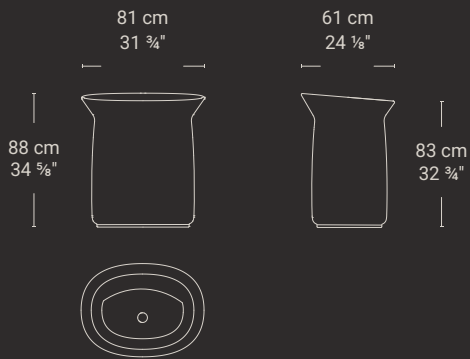

specifiche prodotto/
product specifications

Minimal M6

design by Nespoli e Novara





MINIMAL M6 Lavabo Freestanding /
Freestanding Basin
Marmo Cipollino Misto / Cipollino Misto
marble



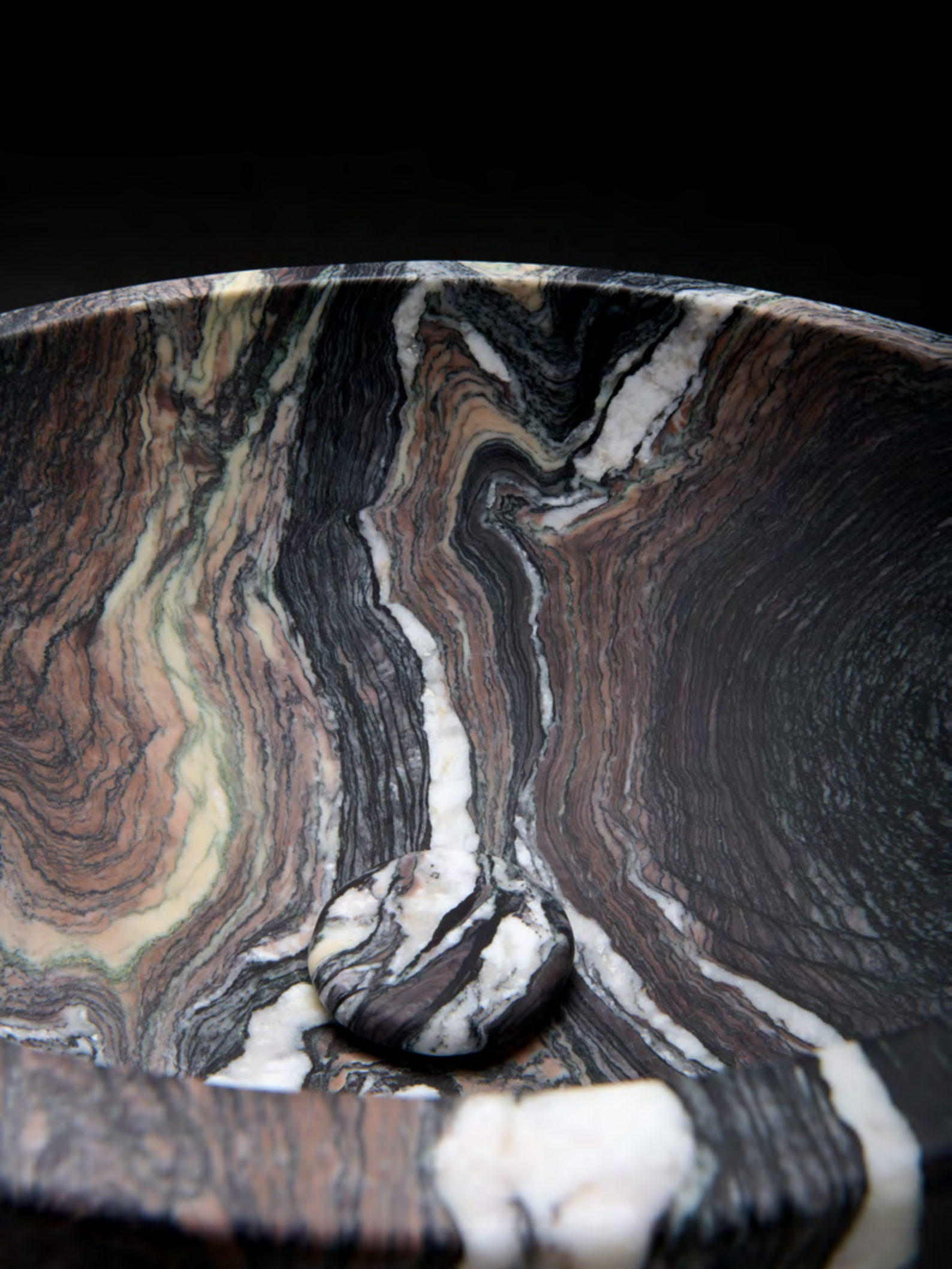



MINIMAL M6 RANDOM Lavabo Freestanding /
Freestanding Basin
Marmo Verde Antigua / Verde Antigua marble

Minimal M6

Lavabo, design by Nespoli e Novara

MINIMAL reinterpreta il concetto di lavabo monolitico attraverso materiali, finiture e lavorazioni sartoriali che, unite ad avanzate tecniche industriali, definiscono una nuova estetica.

Due le versioni proposte: la prima in marmo Verde Antigua, utilizza una speciale lavorazione a spacco (Random) che dà vita ad una superficie cannettata e altamente materica, in grado di trasmettere la qualità di questa lavorazione particolare esaltando le qualità del materiale; la seconda versione vede il lavabo monolitico realizzato in marmo Cipollino misto, con una finitura levigata di alta qualità che combinata con la purezza della forma del volume, promuove un'esperienza sensoriale emotiva profonda. Un progetto che consente al materiale di trasmettere unicità e naturalezza, mantenendo la sua integrità naturale; le caratteristiche intrinseche rafforzano la sensazione di autenticità e connessione con la natura anche all'interno di spazi abitativi.

Washbasin designed by Nespoli e Novara

MINIMAL redefines the idea of the monolithic basin and establishes new aesthetics using materials, finishes, and bespoke craftsmanship combined with cutting-edge industrial techniques.

Two models are available - the first, crafted from Verde Antigua marble, is made using a unique split processing technique (Random) that results in a ribbed and highly textured surface. This enhances the material's qualities and conveys the excellence of this process.

The second model features a monolithic basin made from Cipollino Misto marble, with a superior polished finish. This, coupled with the purity of the shape, provides a deep sensory experience.

The design allows the material to express its uniqueness and naturalness while preserving its inherent integrity. Its features amplify the sense of authenticity and connection to nature which can be enjoyed in residential spaces.

Minimal M6

<u>MINL001</u>	Minimal M6 Random Lavabo Freestanding D45x85 Minimal M6 Random Freestanding Basin D45x85
<u>MINL002</u>	Minimal M6 Random Lavabo Freestanding D45x85 scarico a parete Minimal M6 Random Freestanding Basin D45x85 wall drain
<u>MINF001</u>	Minimal M6 Lavabo Freestanding D45x85 Minimal M6 Freestanding Basin D45x85
<u>MINF002</u>	Minimal M6 Lavabo Freestanding D45x85 scarico parete Minimal M6 Freestanding Basin D45x85 wall drain

specifiche prodotto/
product specifications

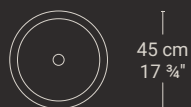
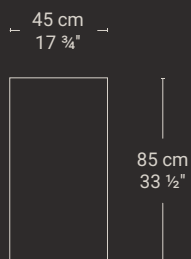

Alone

design by Nespoli e Novara





Alone

bathtubs/vasche



ALONE Vasca Freestanding / Freestanding Bathtub
Marmo Star Gold / Star Gold marble

303

Alone

Vasca, design by Nespoli e Novara

Dal design firmato Nespoli e Novara una vasca in pietra naturale e marmo assolutamente unica, per la raffinata asimmetria della forma e la natura dei materiali. NEUTRA ALONE si sviluppa infatti in due curve avvolgenti di diversa ampiezza che si congiungono sinuosamente, per ricreare una linea di morbida eleganza nella quale abbandonarsi al piacere senza tempo di una superficie in pietra perfettamente liscia e uniforme.

Bathtub designed by Nespoli e Novara

By the designers Nespoli and Novara here is a bathtub made of natural stone and marble, its sophisticated asymmetric shape and the origin of its material make it unique. Two embracing curves of different sizes sinuously rejoined to give shape to NEUTRA ALONE, whose curves create a soft and elegant line, where you relinquish yourself to the timeless pleasure of a perfectly smooth and uniform stone surface.

Alone

ALOV001 Alone Vasca Freestanding 190x90x50
Alone Freestanding Bathtub 190x90x50

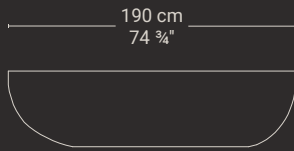

Daphne

design by STUDIOPIVA

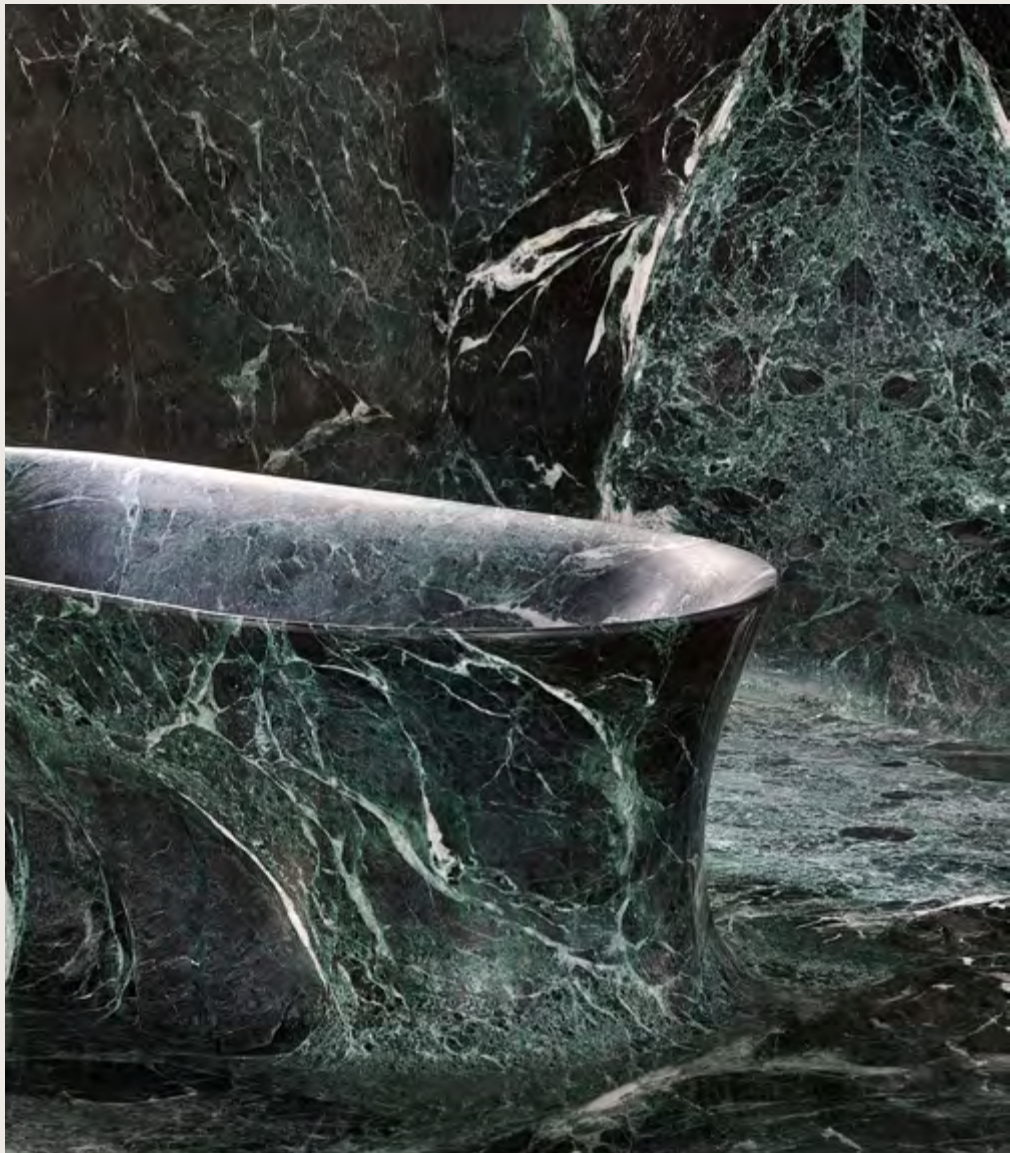





DAFNE Vasca da incasso/ Built-in Bathtub
Marmo Verde Alpi / Verde Alpi marble

Daphne

Vasca e rivestimenti per l'ambiente bagno,
design by STUDIOPIVA.

EDIZIONE LIMITATA 25 PEZZI

Il progetto nasce dall'idea di integrare l'elemento vasca nell'architettura dello spazio con un approccio scultoreo. Ha come nume tutelare la ninfa omonima, personaggio del mito greco associato ai corsi d'acqua dolce, alle sorgenti e ai ruscelli.

Fulcro del sistema è una vasca monumentale in marmo Verde Alpi, disponibile anche in altre varianti di marmo, che si innalza, senza interruzioni, dal piano del pavimento.

La forma del bacino si ispira al movimento dell'acqua nel momento esatto in cui una goccia cade sulla superficie liquida. La conformazione e le proporzioni perfettamente bilanciate, le lavorazioni che conferiscono morbidezza ai profili e ai bordi, rendono la vasca un'opera quasi contemplativa.

Il contrasto tra le finiture delle superfici in marmo anima un gioco di riflessi: l'esterno è lucido, mentre l'interno è opaco e riacquisterà poi un effetto lucido una volta che la vasca sarà riempita d'acqua.

La pavimentazione si estende anche alla dimensione verticale, grazie a un raffinato rivestimento parietale.

È previsto lo sviluppo di elementi ad angolo - che creano un gioco di continuità tra la superficie del pavimento e le pareti, nonché tra le pareti stesse - oltre a lavabi.

Daphne è il risultato di un lungo e complesso processo di produzione che ha richiesto 300 ore di lavorazioni in macchina e 150 ore di lavorazione manuale, combinando sofisticate tecnologie con accurate finiture artigianali. Il materiale di scarto verrà riutilizzato per altri complementi d'arredo.

Disponibile anche nella versione da appoggio.

Daphne

Bathtub and wall & floor coverings for the bathroom designed by STUDIOPIVA.

LIMITED EDITION 25 PIECES

The design stems from the idea of integrating the bathtub element into the space architecture with a sculptural approach. The nymph's name inspired this bathtub, a character from Greek myth associated with freshwater courses, springs and streams.

The system's centrepiece is a monumental Verde Alpi marble bathtub which rises from the floor.

This is available in other marble options.

The bathtub shape is inspired by the movement of water at the exact moment when a drop falls onto the liquid surface.

The perfectly balanced shape and proportions, the artwork that lends softness to the contours and edges make the bathtub an almost contemplative work.

The contrast between the marble surface finishes animates reflections - the outside is shiny, while the inside is matt which regains its shiny effect once the bathtub is filled.

The flooring extends vertically, using a refined wall covering. In addition to wash-basins, there are corner elements which create continuity between the floor and walls, and between walls.

Daphne is the result of a long and complex production process that took 300 hours of machine work and an additional 150 hours of manual work, combining sophisticated technologies with handmade finishes. The waste material will be reused for other furnishings.

Also available in the free-standing version.

specifich prodotto /
product specifications

Daphne

DAPV001 Daphne Vasca freestanding 194x94x56
Daphne freestanding bathtub 194x94x56
LIMITED EDITION 25 PCS.

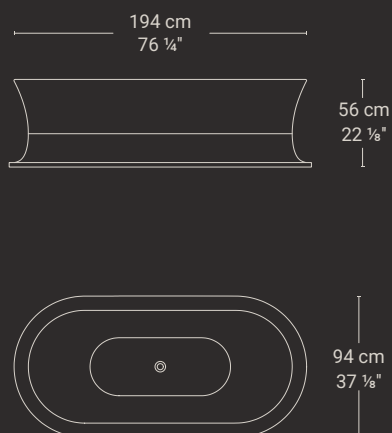

DAPV002 Daphne Vasca da incasso 200x100x55
Daphne built-in bathtub 200x100x55
LIMITED EDITION 25 PCS.

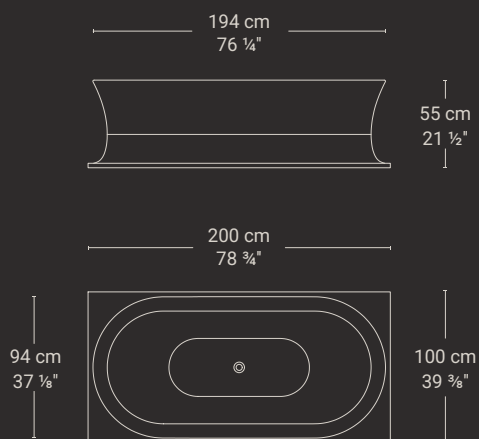

Duo

design by Matteo Thun & Antonio Rodriguez







DUO Vasca Freestanding / Freestanding Bathtub
Marmo Super White / Super White marble

Duo

Vasca, design by Matteo Thun & Antonio Rodriguez

Da un pioniere del design sostenibile come Matteo Thun e dal suo talentuoso partner Antonio Rodriguez, ecco un'opera nella quale scorre l'eterna e ideale armonia tra natura e arte. La pietra naturale è l'elemento millenario che dà vita a una vasca che emerge per le sue equilibrate ed autentiche composizioni.

Bathtub designed by Matteo Thun & Antonio Rodriguez

From a pioneering designer such as Matteo Thun and his talented partner Antonio Rodriguez, here comes a piece of work where the eternal and ideal harmony between nature and peace flows. The natural stone is an ancient material that gives form to a bathtub, which stands out for its balanced and original composition.

Duo

DUOV007

Duo Vasca Freestanding 180x90x55
Duo Freestanding Bathtub 180x90x55

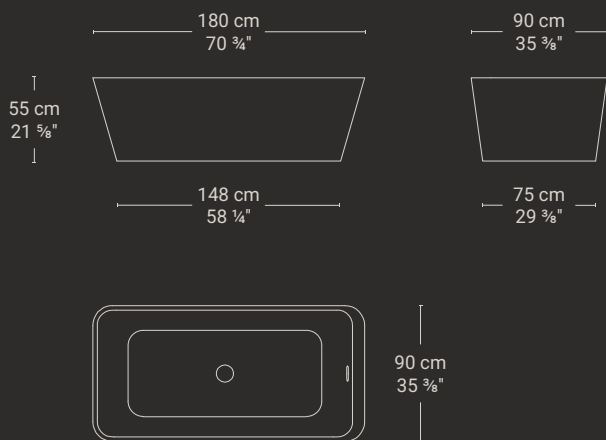

specifiche prodotto/
product specifications

Easy

design by **Nespoli e Novara**





Easy

bathtubs/vasche



EASY Vasca Freestanding / Freestanding Bathtub
Marmo Grigio Orobico / Grigio Orobico marble

319

Easy

Vasca, design by Nespoli e Novara

Pura esaltazione della semplicità minimale, EASY è il modello NEUTRA firmato dai designer Nespoli e Novara dalla forma più regolare e definita.

La sua rigorosa e accogliente geometria rettangolare si "incastra" con esclusività e ricercatezza in ogni ambiente bagno, donando allo spazio un'oasi di puro e semplice benessere.

Bathtub designed by Nespoli e Novara

A pure celebration of minimalist simplicity, EASY is the NEUTRA model designed by Nespoli and Novara with a more conventional and defined shape.

Its rigorous yet pleasant rectangular shape makes it fit for every bathroom, giving an oasis of pure and simple well-being to the environment.

Easy

EASV001 Easy Vasca Freestanding 180x80x50
Easy Freestanding Bathtub 180x80x50

180 cm
70 7/8"

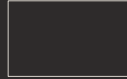
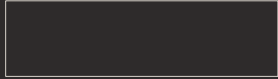

50 cm
19 5/8"

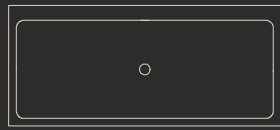

80 cm
31 1/2"

specifiche prodotto/
product specifications

Inkstone

design by Steve Leung



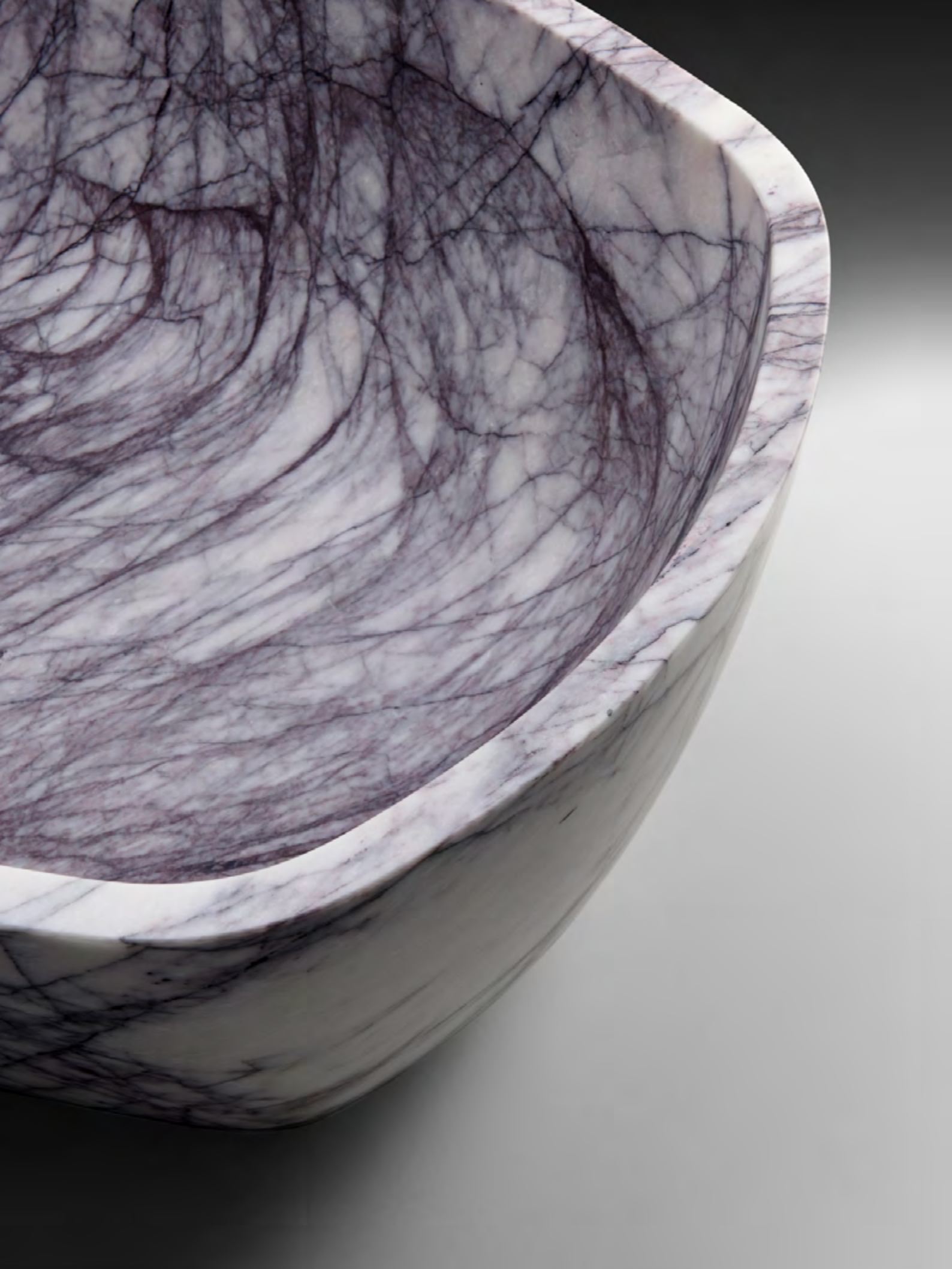



INKSTONE Vasca Freestanding / Freestanding Bathtub
Marmo Lilac / Lilac marble

Inkstone

Vasca, design by Steve Leung

Dalla firma inconfondibile del designer di Hong Kong Steve Leung, nasce una vasca di design in pietra naturale che racchiude tutta l'arte e la filosofia asiatiche. Elemento di punta di una collezione ispirata alla pietra da inchiostro cinese, NEUTRA INKSTONE narra l'oriente e la sua minimale eleganza per far emergere la ricercatezza di un tratto che definisce un profondo benessere fisico e mentale. INKSTONE sa avvolgere subito la mente e lo spirito attraverso la sobrietà delle sue linee minimali, evidenziando al tatto la naturale purezza di ognuna delle pietre da cui può prendere forma.

Bathtub designed by Steve Leung

A designer bathtub made of natural stone which bears the hallmarks of Asian art and philosophy originates from the unique hands of Steve Leung, a designer from Hong Kong. Key element of a collection that is inspired by Chinese inkstone, NEUTRA INKSTONE tells us about the East and its minimalist elegance. Its material enhances the refined trait that defines a deep physical and mental well-being. INKSTONE can wrap your mind and spirit at once thanks to its simple lines, giving you the opportunity to touch the natural pureness of the stones selected to create it.

Inkstone

INKV005

Inkstone Vasca Freestanding 180x100x50
Inkstone Freestanding Bathtub 180x100x50

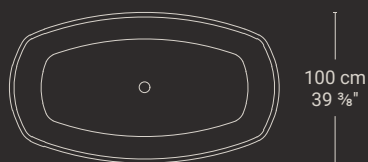

specifche prodotto/
product specifications

Majesté

design by Monica Armani







MAJESTÉ Vasca Freestanding / Freestanding Bathtub
Marmo Verde Borgogna / Verde Borgogna marble
Accessori Zucchetti / Zucchetti accessories



Majesté

Vasca, design by Monica Armani

EDIZIONE LIMITATA 25 PEZZI

Majesté si compone di una vasca e un lavabo monolitici, accompagnati da un maestoso specchio (tondo oppure ovale). La collezione modella la pietra sul concetto di regalità, una visione che trasforma il bagno in un regno esclusivo e senza tempo. Le forme scultoree, morbide e avvolgenti, rivelano la bellezza della materia. Proprio la preziosità del marmo ha ispirato Monica Armani ad immaginare la vasca e il lavabo dotati di un colletto "sparato", tipico degli abiti regali dei nobili, che diventa un elemento di accoglienza, un invito a entrare in un ambiente dove l'eleganza si fonde con la forza primordiale della natura.

Ogni superficie, ogni curva racconta una storia di maestosità, e ogni dettaglio riflette la lucentezza intramontabile di una pietra che si lascia modellare dal tempo senza mai perderne la forza.

Bathtub designed by Monica Armani

LIMITED EDITION 25 PIECES

The Majesté collection is composed of a monolithic bathtub and washbasin, accompanied by a majestic mirror (round or oval). A vision born from an encounter between stone and the concept of royalty, the bathroom is transformed into an exclusive and timeless realm. Soft and enveloping sculptural forms appear to emerge from the stone itself, as if the material had chosen to unveil itself under the sign of beauty. Inspired by the preciousness of marble, Monica Armani imagined a bathtub and washbasin with a 'shot' collar, typical of the royal robes worn by nobility, as a welcoming element and invitation to enter an environment where elegance merges with the primordial force of nature. Every surface, every curve tells a majestic story, with each single detail reflecting the timeless brilliance of a stone that lets itself be shaped by time without ever losing its strength.

specifiche prodotto/
product specifications

Majesté

MAJB001 Majesté Vasca Freestanding 214x114x62
Majesté Freestanding Bathtub 214x114x62

EDIZIONE LIMITATA 25 PZ. / LIMITED EDITION 25 PCS.

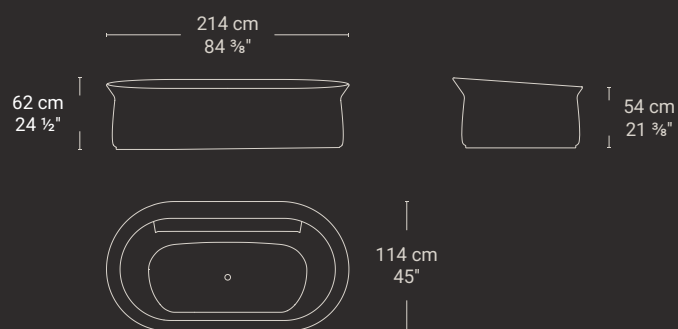

Spa

design by Nespoli e Novara





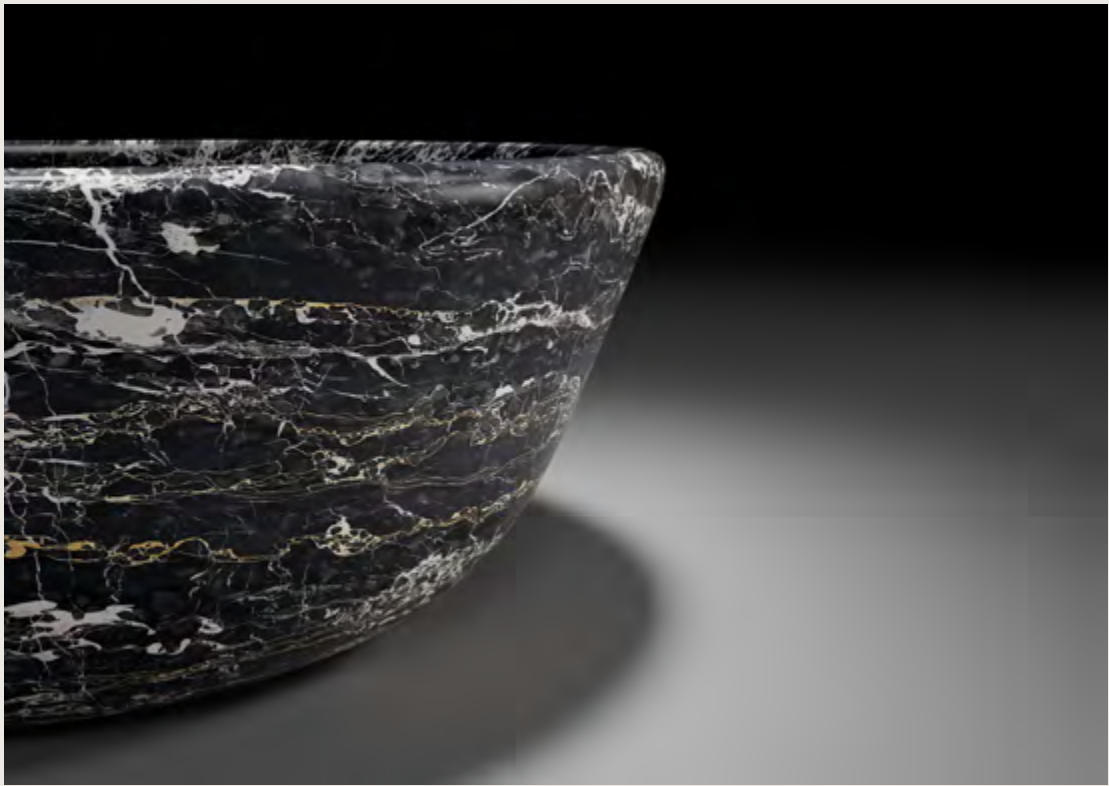

SPA Vasca Freestanding / Freestanding Bathtub
Marmo Portoro Silver / Portoro Silver marble

Spa

Vasca, design by Nespoli e Novara

Una circolarità assoluta e senza tempo, per un modello esclusivo delle vasche di design NEUTRA firmate da Nespoli e Novara.

La forma perfettamente tonda e le linee avvolgenti e morbide della pietra naturale di SPA sanno circondare ogni senso in una curva continua che porta all'estremo relax e comfort. Un elemento assoluto di interior design, protagonista di ambienti solari e luminosi e dalle suggestive atmosfere vaporose.

Bathtub designed by Nespoli e Novara

A perfect, circular and timeless shape for an exclusive model of NEUTRA's bathtubs designed by Nespoli and Novara.

The perfectly round shape and the soft and embracing lines of SPA's natural stone can surround every sense in a relaxing and comfortable curve. This is an absolute piece of interior design, the protagonist of sunny and bright environments, with evocative steamy atmospheres.

Spa

SPAV001

Spa Vasca Freestanding D165x60
Spa Freestanding Bathtub D165x60

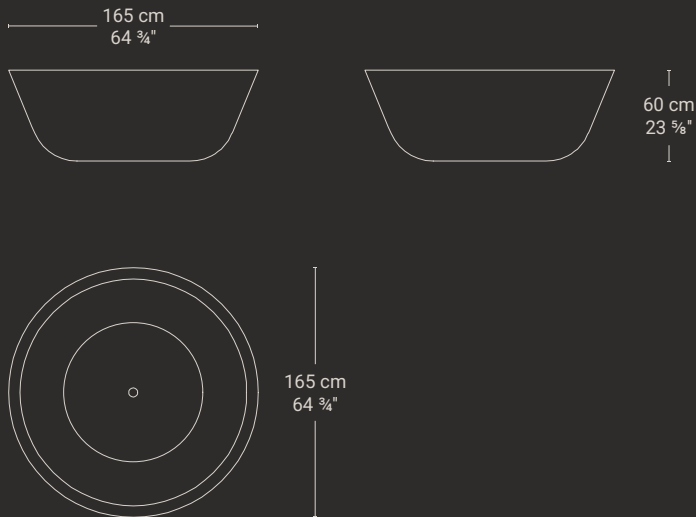

specifiche prodotto/
product specifications

Venus

design by CRS NEUTRA



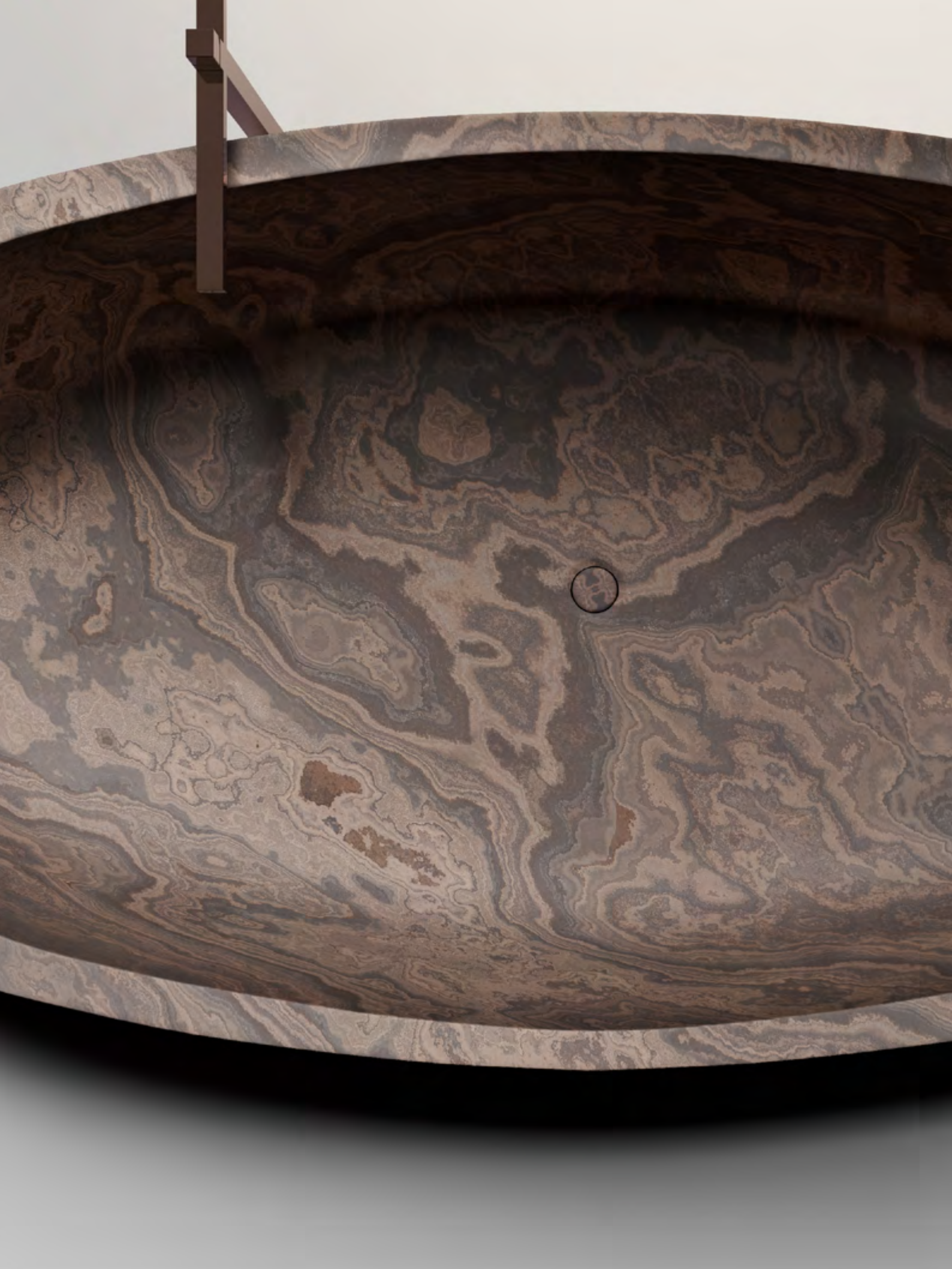



Venus

bathtubs/vasche



VENUS Vasca Freestanding / Freestanding Bathtub
Marmo Tobacco Brown / Tobacco Brown marble

Venus

Vasca, design by CRS NEUTRA

Vasca di design con o senza sistema idromassaggio ad aria, realizzata da un blocco unico di marmo, VENUS rappresenta una soluzione bagno di assoluto pregio estetico e progettuale per ambienti wellness e spa privati. Un modello freestanding dalla forma ovale perfettamente disegnata, morbida e delicata come ognuna delle nove pietre naturali dalle quali può nascere.

Per un'opera di grande fascino firmata dal Centro di Ricerca e Sviluppo NEUTRA, risultato di una lavorazione artigianale ricercata in ogni dettaglio, e in ogni venatura.

Bathtub designed by CRS NEUTRA

A design bathtub with or without airpool system, created from a single block of marble, VENUS is the perfect solution for private wellness and spa environments, thanks to its design and aesthetic features. A freestanding tub with a perfectly designed oval shape, which is soft and delicate like each of the nine natural stones it can be made from.

A work of great appeal designed by NEUTRA's R&D centre (CRS), which is the result of a refined artisanal manufacturing that shows attention to every meticulous detail.

Venus

VENV001 Venus Vasca Freestanding 180x90x58
Venus Freestanding Bathtub 180x90x58

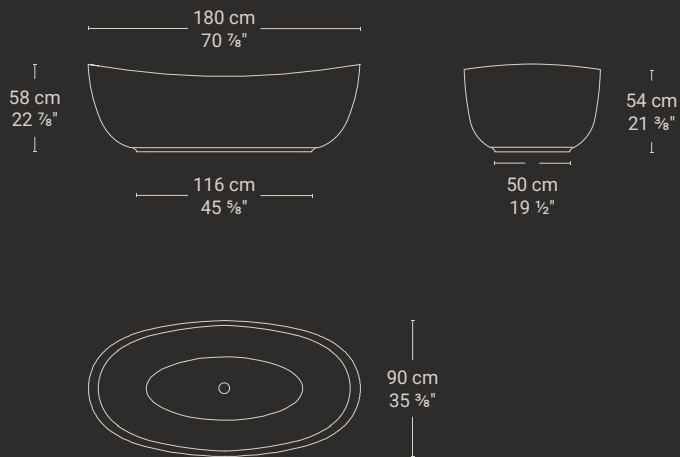

VENV002 Venus Vasca Freestanding Idromassaggio 180x90x58
Venus Freestanding Bathtub Hydromassage 180x90x58

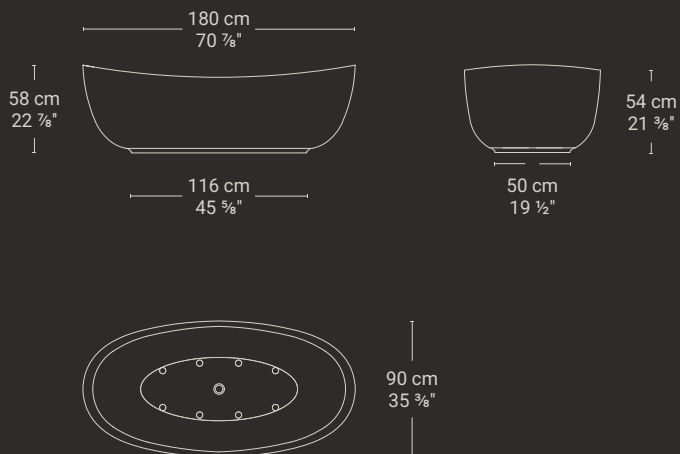

Majesté

design by Monica Armani



Majesté



MAJESTÉ Mirror 150x215
Marmo Verde Borgogna / Verde Borgogna marble

Majesté

Specchio, design by Monica Armani

Majesté si compone di una vasca e un lavabo monolitici, accompagnati da un maestoso specchio (tondo oppure ovale). La collezione modella la pietra sul concetto di regalità, una visione che trasforma il bagno in un regno esclusivo e senza tempo. Le forme scultoree, morbide e avvolgenti, rivelano la bellezza della materia. Proprio la preziosità del marmo ha ispirato Monica Armani ad immaginare la vasca e il lavabo dotati di un colletto "sparato", tipico degli abiti regali dei nobili, che diventa un elemento di accoglienza, un invito a entrare in un ambiente dove l'eleganza si fonde con la forza primordiale della natura.

Ogni superficie, ogni curva racconta una storia di maestosità, e ogni dettaglio riflette la lucentezza intramontabile di una pietra che si lascia modellare dal tempo senza mai perdere la forza.

Mirror designed by Monica Armani

The Majesté collection is composed of a monolithic bathtub and washbasin, accompanied by a majestic mirror (round or oval). A vision born from an encounter between stone and the concept of royalty, the bathroom is transformed into an exclusive and timeless realm. Soft and enveloping sculptural forms appear to emerge from the stone itself, as if the material had chosen to unveil itself under the sign of beauty. Inspired by the preciousness of marble, Monica Armani imagined a bathtub and washbasin with a 'shot' collar, typical of the royal robes worn by nobility, as a welcoming element and invitation to enter an environment where elegance merges with the primordial force of nature. Every surface, every curve tells a majestic story, with each single detail reflecting the timeless brilliance of a stone that lets itself be shaped by time without ever losing its strength.

Majesté

specifichè prodottò/
product specifications

MAJC001 Majesté Mirror 200x50x220

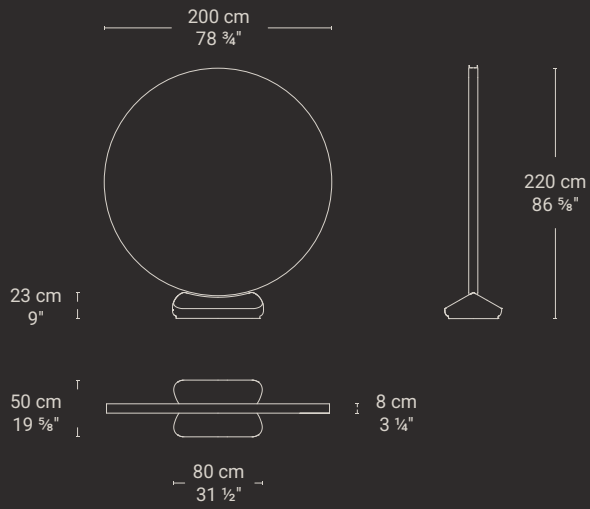

MAJC002 Majesté Mirror 150x50x215

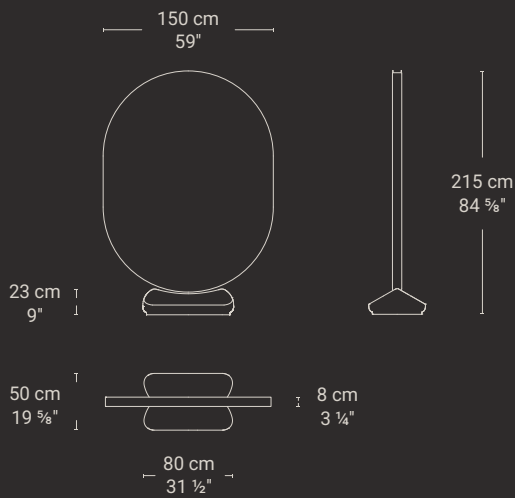

Vivera

design by Migliore+Servetto

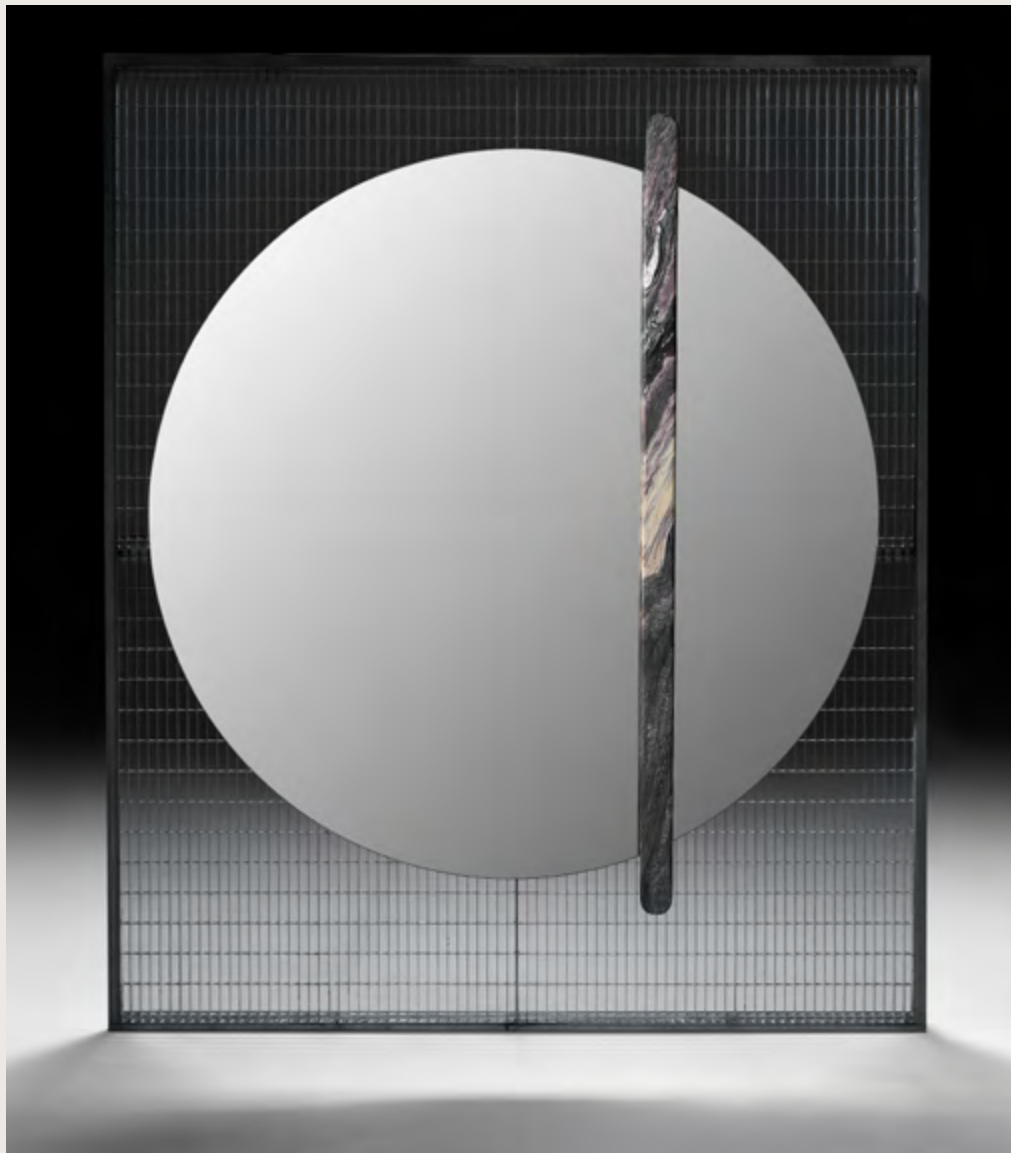



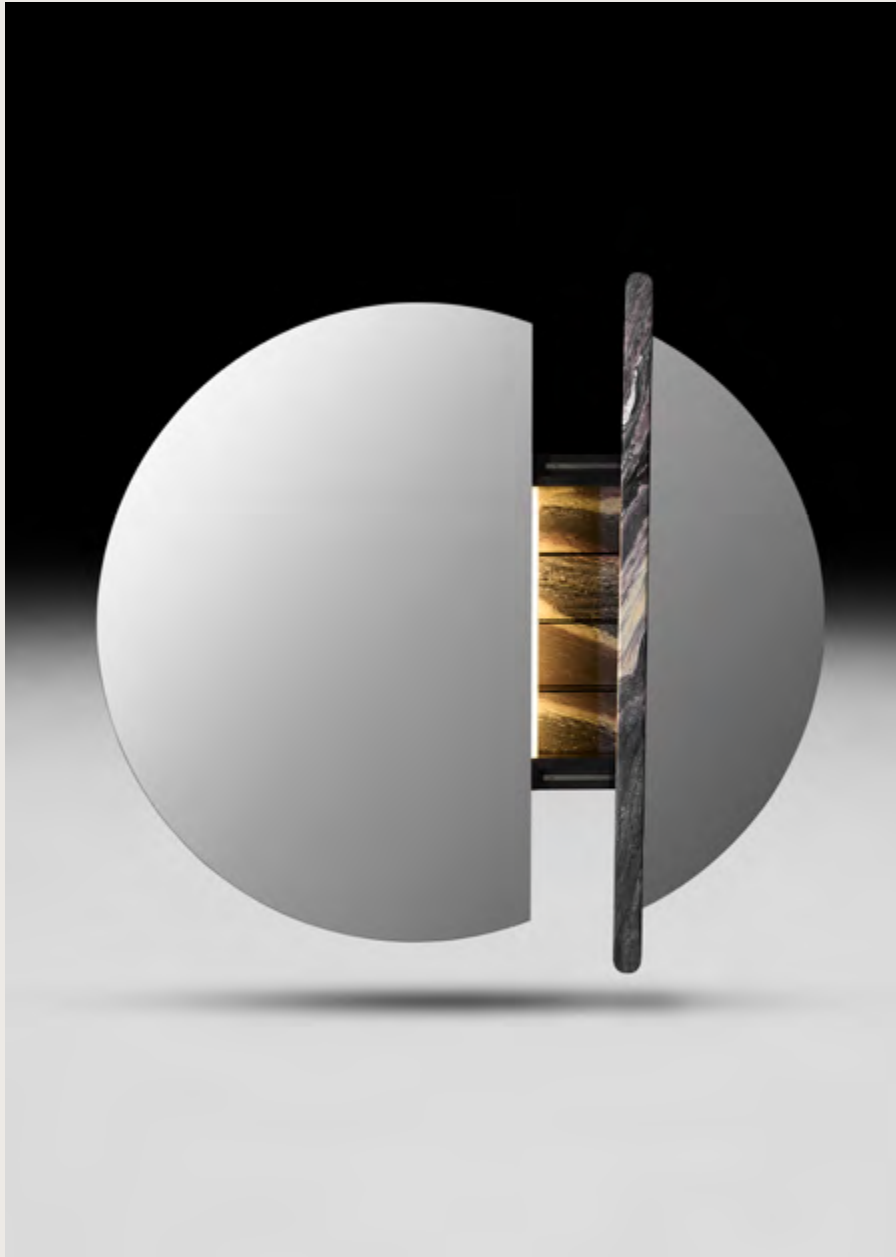

VIVERA Specchiera / Mirror
Marmo Cipollino Misto, glass fumé, acciaio
effetto calamina / Cipollino Misto marble,
Smoked glass and Steel with a calamina finish



Vivera

Specchiera, design by Migliore+Servetto

VIVERA è una monumentale specchiera circolare in glass fumé e acciaio effetto calamina, che si caratterizza per la presenza di un vano di contenimento con una grande maniglia in marmo Cipollino Misto a guidare l'anta a scorrimento.

VIVERA è dotata di illuminazione integrata: il movimento dell'anta scorrevole rivela una prima sorgente luminosa per l'illuminazione diretta del volto; una seconda luce radente sulla sinistra illumina il vano e il marmo che fa da sfondo; infine, sul retro della specchiera, una luce effetto wall-washer definisce su tutto il perimetro dell'oggetto un'illuminazione tenue e scenografica.

Mirror designed by Migliore+Servetto

VIVERA stands as an imposing round mirror, crafted from smoked glass and steel with a calamina finish.

It has a storage compartment with a large handle made from Cipollino Misto marble, which directs the sliding door's movement.

VIVERA features built-in lighting: as the sliding door opens, it exposes a first light that directly brightens the face. Additionally, a second grazing light on the left side lights up the compartment and the marble backdrop, while a wall-washer light behind the mirror creates a gentle and dramatic glow along the object's edges.

VIVS001 Vivera Specchiera 175x190x26
Vivera Mirror 175x190x26

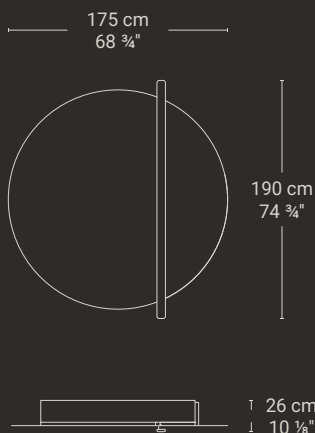

*La collezione Vivera è disponibile su richiesta in diversi marmi e metalli, previa verifica tecnica.
The Vivera collection is available on request in different marbles and metals, after technical testing.*

Monica Armani



Established in 1996
Trento, Italy

www.monica-armani.com

atelier oi



Established in 1991
La Neuveville, Switzerland

www.atelier-oi.ch

Mario Bellini



Established in 1980
Milan, Italy

www.bellini.it

Gabriele e Oscar Buratti



Established in 1992
Milan, Italy

www.burattiarchitetti.it

Draw Studio



Established in 2018
Bolzano and Empoli, Italy

www.drawstudio.eu

Stefano Gallizioli



Established in 1997
Milan, Italy

www.stefanogallizioli.it

Steve Leung



Established in 1997
Hong Kong and Shanghai, China

www.sldgroup.com

Migliore+Servetto



Established in 1997
Milan, Italy

www.miglioreservetto.com

Nespoli e Novara



Established in 2000
Seregno, Italy

www.nespolinovara.com

STUDIOPIVA



Established in 2018
Wien, Austria

www.studiopiva.eu

Matteo Thun & Antonio
Rodriguez



Established in 1984
Milan, Italy

www.matteothun.com

Zaha Hadid Architects



Established in 1980
London, UK

www.zaha-hadid.com

Photographers

Nicola Colia, pp. 33-35, 40-43, 59-63, 133-135, 170, 279-283.

Gianluca Di Ioia, pp. 87-91, 156, 159, 161, 272-275.

Andrea Martiradonna, p. 56.

Bruno Pulici, p. 201.

Leo Torri Studio, pp. 7-10, 13-15, 18-20, 23-27, 30-32, 46-49, 52-53, 55, 57, 67-70, 72-76, 79-83, 95-97, 100-102, 106-107, 110-113, 117-121, 136-140, 157-158, 160, 175, 181-184, 187-189, 192-195, 199-200, 204-208, 210-212, 216-217, 224-228, 232-233, 242-248, 252-253, 257-258, 261-264, 267-269, 276, 287-291, 294-298, 306-308, 322-324, 327-330, 344-345, 348-351.

NEUTRA

NEUTRA srl
via Parigi 30
20831 Seregno MB
Italy

T +39 0362 327962
T +39 0362 246708
info@neutradesign.it

neutradesign.it
@ neutra.design